

Crane Control Class 6715

Catalog

03

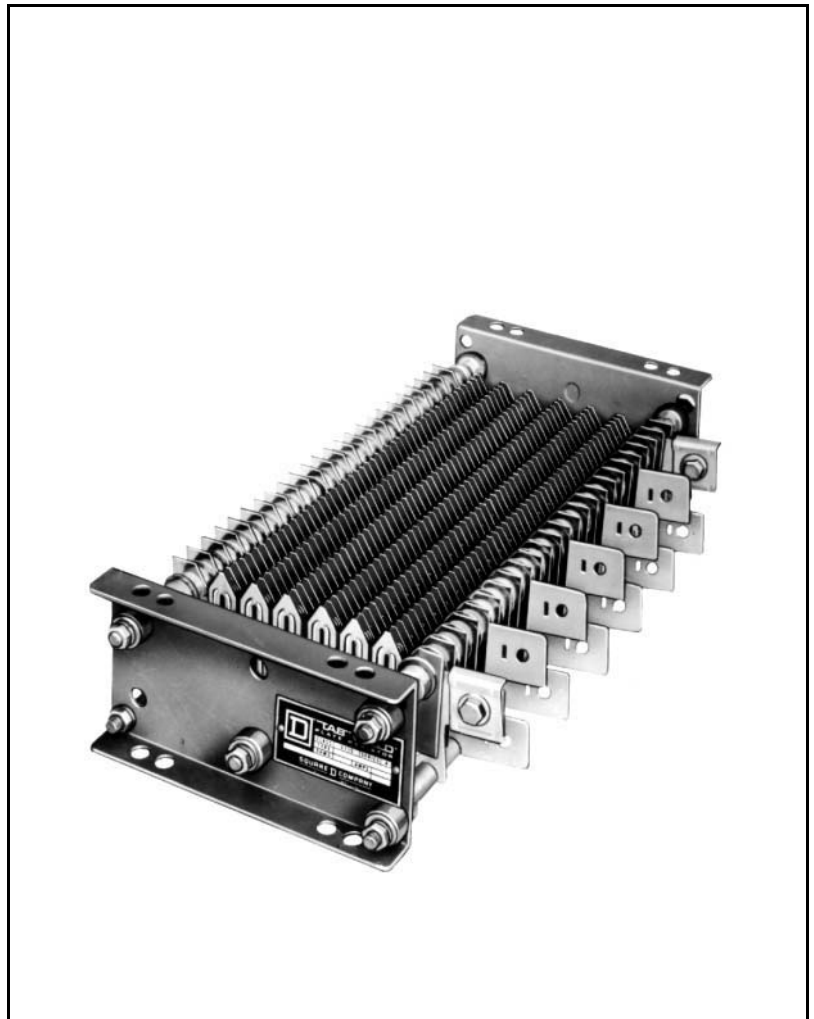

CONTENTS

Description	Page
Pricing and Ordering Information	86
Application Data	89
Dimensions and Weights	90



The Electric Controller and
Manufacturing Company, LLC

CRANE CONTROL
CLASS 6715

Crane Control Class 6715 Tab-Weld® Resistors

PRICING AND ORDERING INFORMATION

- Stainless steel alloy grids
- Applicable where environmental conditions of vibration and dirt are severe
- The standard resistor section is supplied with 2 terminals



**Class 6715
Type TW100D
Resistor**

Volts	Continuous Ampere Capacity (375 °C Rise)	Resistance Between Taps †	26-1/2" Section ▲			18" Section ▲			Extra Unmounted Terminals	
			Total Resistance†	Type	Price	Total Resistance†	Type	Price	Type	Price
600 VAC or VDC max.	500	0.0039	0.0214	TW500D	\$ 1125.	T1	\$ 36.
	430	0.0051	0.0306	TW430D			
	360	0.0072	0.0432	TW360D			
	280	0.0088	0.0748	TW280D		T2	18.
	220	0.014	0.126	TW220D			
	180	0.022	0.198	TW180D			
	150	0.021	0.231	TW150D	1035.	0.126	TW150E	\$ 630.	T3	14.
	120	0.031	0.341	TW120D		0.186	TW120E			
	100	0.042	0.504	TW100D		0.252	TW100E			
	85	0.057	0.741	TW85D	1035.	0.399	TW85E			
	72	0.073	1.022	TW72D		0.511	TW72E	630.		
	62	0.17	1.445	TW62D		0.680	TW62E			
	50	0.30	2.55	TW50D	1035.	1.20	TW50E	630.		
	42	0.36	4.14	TW42D		2.16	TW42E			
	32	0.58	6.96	TW32D		3.77	TW32E			
	37	0.118	5.20	TW37D	1260.	2.83	TW37E	810.	T4	9.
	27	0.217	9.55	TW27D		5.20	TW27E			
	21	0.350	15.75	TW21D		8.75	TW21E			
16	0.560	25.20	TW16D	14.00		TW16E				
13	0.850	40.00	TW13D	22.10		TW13E				

† Ohms at 25 °C.

▲ Consult factory for 12" resistor sections.



PRICING AND ORDERING INFORMATION

Resistors with Isolated Sections

Resistors with either 2 or 3 isolated sections can be provided for use as the accelerating resistor in the secondary of an AC wound rotor motor, where isolated sections are needed for each rotor phase. The D3 resistor is divided into 3 isolated sections of equal resistance. The D2 resistor is divided into 2 isolated sections. The resistance of one portion is twice the resistance of the other portion.

The price includes:

- 1 D2 or D3 resistor sections
- 4 Terminals (D2 sections only)
- 6 Terminals (D3 sections only)



**TW27D2 Resistor
with 2 isolated sections**

Volts	Continuous Ampere Capacity (375 °C Rise)	Resistance Between Taps †	26-1/2" D2 Section				26-1/2" D3 Section			Extra Unmounted Terminals	
			Resistance †		Type	Price	Resistance †	Type	Price	Type	Price
			Total in Section 1	Total in Section 2							
600 VAC or VDC max.	50	0.300	1.65	0.75	TW50D2		0.75 ▲	TW50D3			
	42	0.362	2.52	1.26	TW42D2	\$ 1035.	1.08	TW42D3	\$ 1035.	T3	\$ 14.
	32	0.584	4.35	2.03	TW32D2		1.74	TW32D3			
	37	0.118	3.30	1.66	TW37D2		1.42	TW37D3			
	27	0.217	6.08	3.04	TW27D2		2.60	TW27D3			
	21	0.350	9.80	4.90	TW21D2	1260.	4.20	TW21D3	1260.	T4	9.
	16	0.560	15.66	7.83	TW16D2		6.71	TW16D3			
	13	0.850		11.90	TW13D3			

† Ohms at 25 °C.

▲ Resistance in middle section is 0.60 Ohm.

Ordering Information Required:

1. For Resistor:
 - a. Class
 - b. Type
 - c. Class and Type of extra unmounted terminals
2. For Rack:
 - a. Class
 - b. Type
 - c. Form

CP9B Discount
Schedule



Crane Control Class 6715 Tab-Weld® Resistors

PRICING AND ORDERING INFORMATION

Resistor Racks

Maximum Number of Resistor Sections	Open Type		General Purpose Enclosure NEMA Type 1 ▲		Outdoor Enclosure NEMA Type 3R ▲	
	Type	Price	Type	Price	Type	Price
4	BRO4	\$ 804.	BRG4	\$ 1152.	BRW4	\$ 1317.
6	BRO6	909.	BRG6	1407.	BRW6	1548.
8	BRO8	1173.	BRG8	1745.	BRW8	1827.
10	BRG10	2268.

▲ Consult factory for continuous resistor applications (such as load banks) in enclosed resistor banks.

Modifications

Expanded Metal Enclosure: Form C – add \$500.00 to BRG list price.

Resistors Mounted in Racks and Wired: Form R – add 15% of total resistor and rack price.

APPLICATION DATA

Ratings

Ampere ratings shown in the first column of the table below are for continuous duty. Intermittent ratings are also shown for the various duty cycles.

NEMA Class No.	9_	11_	13_	14_	15_	16_	17_
Type	Continuous Capacity	5 sec on out of 80 sec	10 sec on out of 80 sec	15 sec on out of 90 sec	15 sec on out of 60 sec	15 sec on out of 45 sec	15 sec on out of 30 sec
TW500_	500	1750	1350	1200	1000	850	700
TW430_	430	1450	1160	1000	850	725	600
TW360_	360	1200	960	850	700	600	500
TW280_	280	900	760	650	530	470	390
TW220_	220	700	600	500	410	375	310
TW180_	180	560	480	400	330	300	250
TW150_	150	485	375	325	275	245	210
TW120_	120	375	300	260	222	197	170
TW100_	100	300	245	217	185	166	140
TW85_	85	265	203	180	153	137	117
TW72_	72	218	175	150	130	116	100
TW62_	62	190	150	132	113	103	90
TW50_	50	143	113	100	86	78	69
TW42_	42	115	95	85	75	68	59
TW32_	32	85	70	65	58	53	45
TW37_	37	100	87	78	68	61	50
TW27_	27	76	63	58	50	45	38
TW21_	21	58	48	44	39	35	30
TW16_	16	44	37	33	29	26	22
TW13_	13	33	27	25	22	20	17

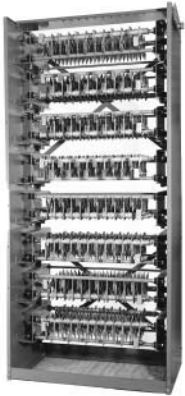

Type BRO8 Open Rack



Type BRG4 General Purpose Enclosure NEMA Type 1



Type BRW6 Outdoor Enclosure NEMA Type 3R

APPLICATION DATA

Resistor Terminals

Type	Resistor Capacity Range	Minimum Wire Size	Maximum Wire Size
T1	500 Amperes	250 MCM	500 MCM
T2	180-430 Amperes	# 1/0	300 MCM
T3	32-150 Amperes	# 2	# 4/0
T4	13-37 Amperes	# 8	# 2

NEMA Service Classifications of Resistors

The numerical portion of the class number refers to the starting current and duty cycle requirements. The letter suffix refers to the special requirements of that resistor based on its application. The letter P denotes reversing plugging service. The letters DL denote dynamic lowering hoist service. When an armature shunt resistor is added to any of the classes, the class number will include the suffix AS. When a dynamic braking resistor is added to any of the classes, the number will include the suffix DB. A class 153P-AS is a reversing plugging resistor which includes an armature shunt and which will allow an initial inrush of 70 percent on a duty cycle of 15 seconds out of 60 seconds with the armature shunt open.

Approximate percent of full load current on first starting point	Class Numbers Applying to Duty Cycles						
	5 sec on out of each 80 sec	10 sec on out of each 80 sec	15 sec on out of each 90 sec	15 sec on out of each 60 sec	15 sec on out of each 45 sec	15 sec on out of each 30 sec	Continuous Duty
25	111	131	141	151	161	171	91
50	112	132	142	152	162	172	92
70	113	133	143	153	163	173	93
100	114	134	144	154	164	174	94
150	115	135	145	155	165	175	95
200 or Over	116	136	146	156	166	176	96

APPROXIMATE DIMENSIONS AND WEIGHTS

Resistor Open Type

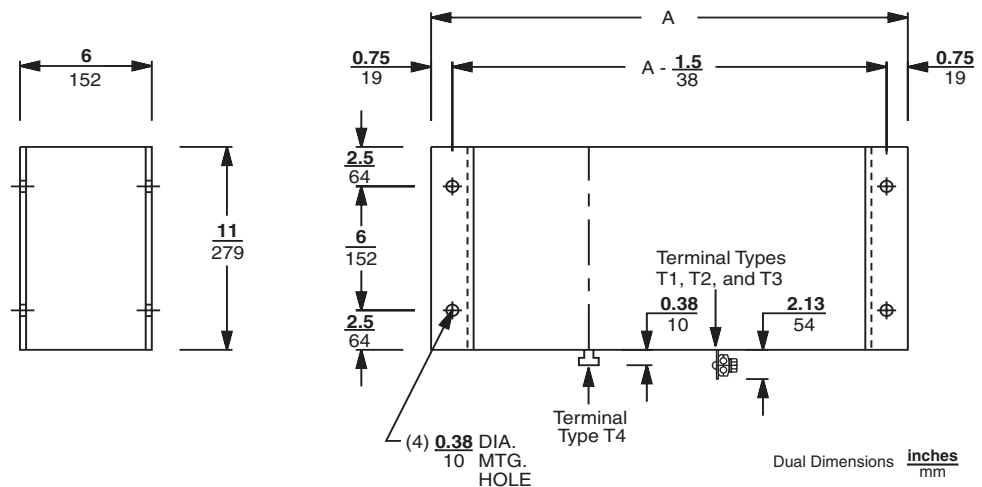

Type Section	A	Net Weight, lbs (kg)
TW_D	$\frac{26.5}{673}$	35 (15.8)
TW_E	$\frac{18}{457}$	22 (9.9)

**CRANE CONTROL
CLASS 6715**



Crane Control Class 6715 Tab-Weld® Resistors

APPROXIMATE DIMENSIONS AND WEIGHTS

Resistor Racks

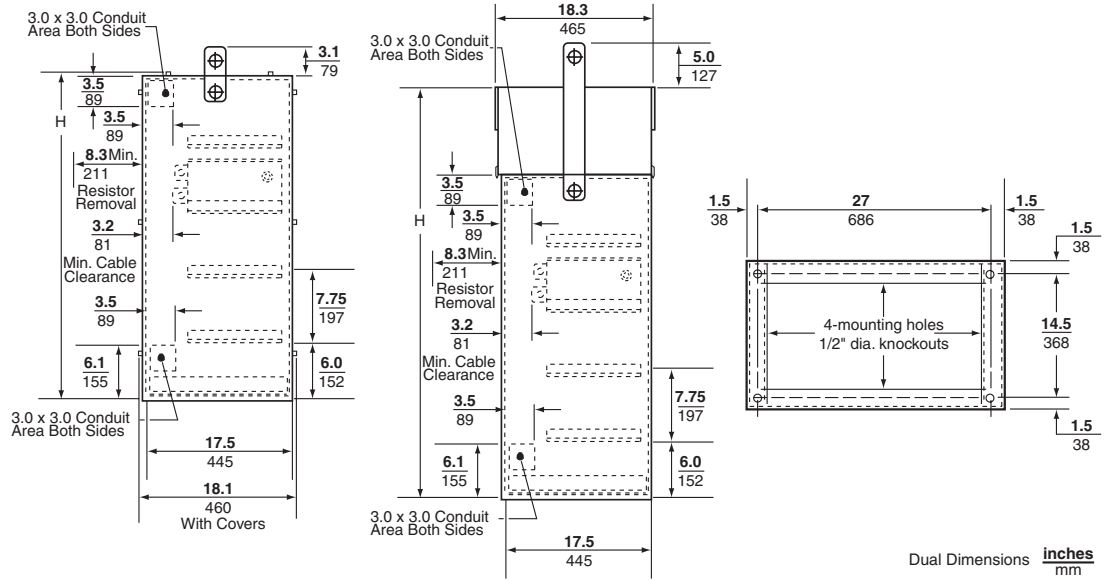

Height H

Max. Number of Resistor Sections	Open Type	General Purpose Enclosure NEMA Type 1	Outdoor Enclosure NEMA Type 3R	Weight Open Style lbs (kg)
4	$\frac{37.4}{950}$	$\frac{37.4}{950}$	$\frac{47.0}{1194}$	50 (22.5)
6	$\frac{52.9}{1344}$	$\frac{52.9}{1344}$	$\frac{62.5}{1588}$	75 (33.8)
8	$\frac{68.4}{1737}$	$\frac{68.4}{1737}$	$\frac{78.0}{1981}$	100 (45.0)
10	—	$\frac{87.5}{2222}$	—	135 (61.2)