

NO. 1 SINGLE POLE L LINE ARC CONTACTOR FRONT CONNECTED FOLIO 3A FOR DC OPERATION

I N S T R U C T I O N S

TYPE L LINE-ARC CONTACTORS are general purpose, direct current magnetic contactors.

Contactor Size		Continuous Rating Amperes	Crane and Mill Rating Amperes	Rupturing Capacity Amperes
NEMA	EC&M			
No. 3	No. 1	100	133	1000

LINE-ARC: These contactors derive their name from the manner in which they handle the arc. The Line-Arc principle of controlling the arc is simple . . . and automatic. There is nothing to adjust or wear out. At the instant the contacts start to separate, the arc is automatically transferred from the contacts to the arcing plate and circular guard over the blowout coil. The arc, as it travels along the arcing plate and circular guard, is stretched out in a line centered between the arc shields. Hence—cool contacts and the name Line-Arc.

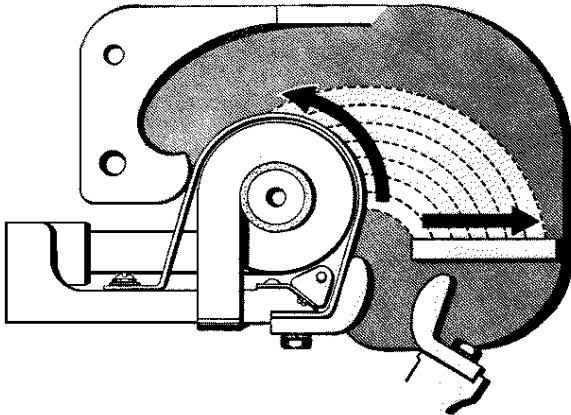

CAUTION—Before operating the contactor under load, be sure that the arc shield is lowered in its proper position.

INSTALLATION: Mount the contactors vertically on rigid supports with at least 3" clearance above and in front of the arc shields to provide the proper distance for arcing clearance and also for removal of the arc shields. The life of the contactor will be considerably prolonged by installing it in a clean, dry place, preferably in a cabinet and as free as possible from external vibration or shock.

MAGNET AIR GAP: To insure quick release of the magnet arm, an air gap of .032" minimum and .047" maximum is provided between the magnet arm and the front ends of the U-shaped frame. See that the magnet faces are free from oil or sticky foreign material.

BEARINGS: Type L contactors are equipped with Nitralloy pins and oil-filled bearings. These bearings are self-lubricating and require no lubrication in the field.

OPERATING COILS: These contactors will operate satisfactorily on 80% of normal control voltage when the coils are hot and will hold in on 20% of normal voltage. The coils will stand 110% of normal voltage continuously.

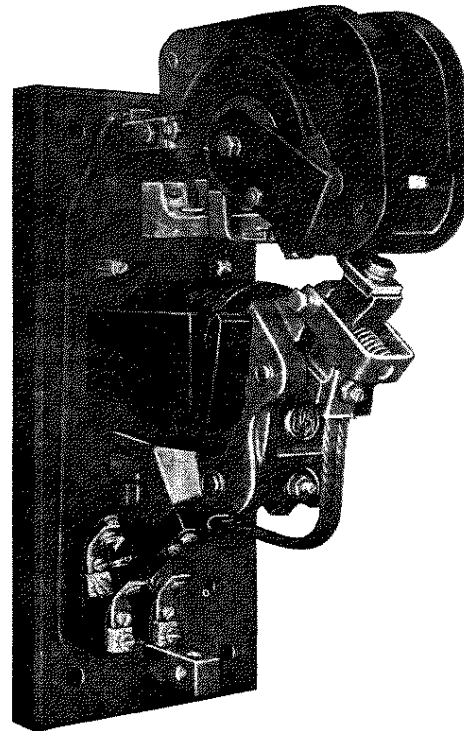

Contactors for 115 and 230 volt service are supplied with continuous capacity coils. Contactors for 550 volt service are supplied with a 230 volt coil and suitable resistor mounted on the back of the base.

To remove the operating coil, first back out the magnet arm pin set-screw and remove the magnet arm pin. The magnet arm may then be lowered to remove the operating coil.

ELECTRICAL INTERLOCKS: These consist of stationary contacts mounted on the base and a moving contact attached to the bottom of the magnet arm. The moving contact should provide 1/8" follow-up when the magnet arm reaches its limit of travel, either completely closed or completely opened. The rating of these electrical interlocks is as follows:

	Max. Inrush	Cont. Amps.	Rupturing Capacity Amps. Inductive			
			115 V.	250 V.	440 V.	550 V.
A.C.	30	15	10	10	5	5
D.C.	30	15	2.5	1.0	.4	.4

(Continued on Page 4)

NEMA SIZE 3 SINGLE POLE L LINE-ARC CONTACTOR, FOLIO 3A

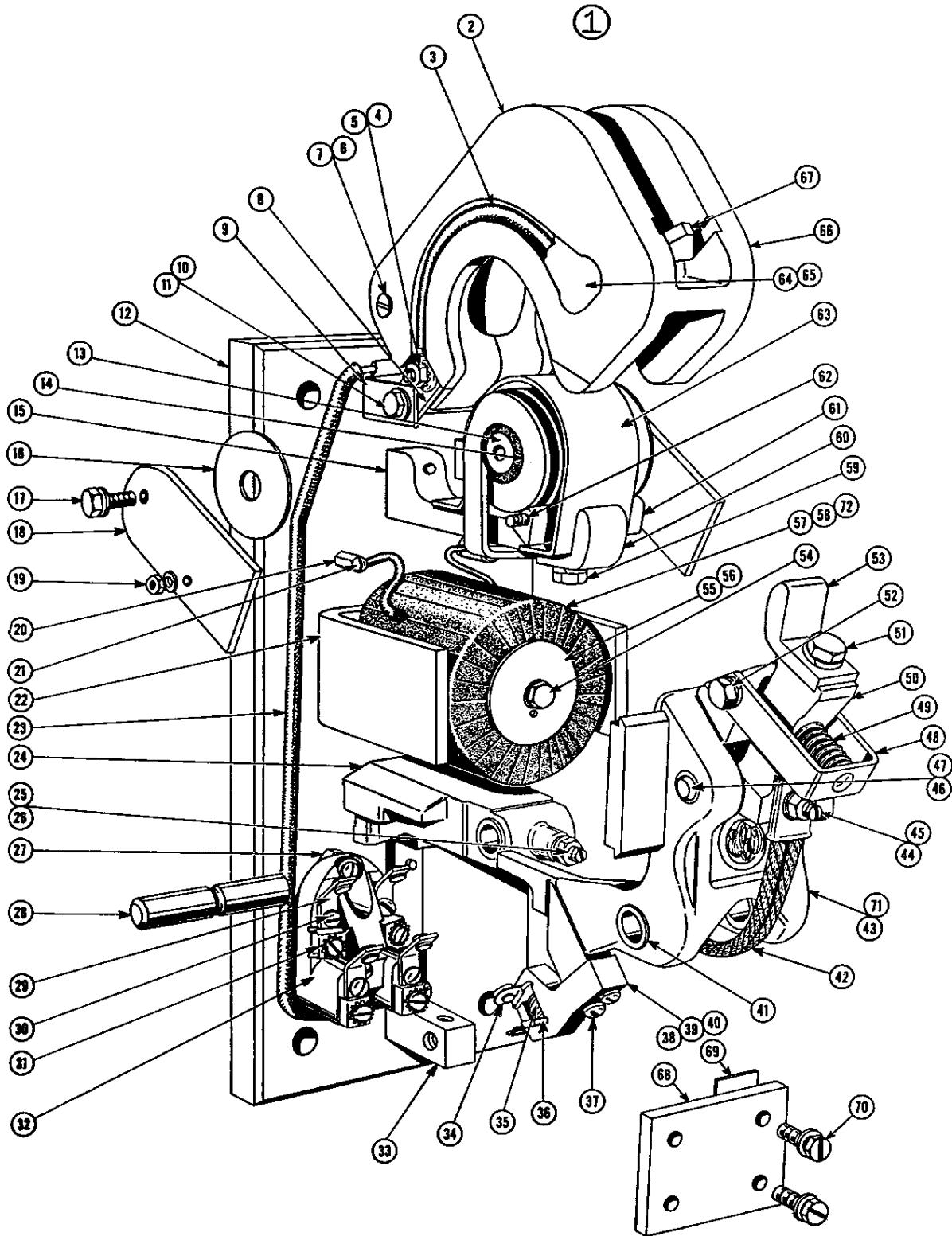

NEMA SIZE 3 SINGLE POLE L LINE-ARC CONTACTOR, FOLIO 3A

Item No.	List No.	Description	Item No.	List No.	Description
1	LT-1024-A	Assembled Arc Shield, Complete.....	36	EL-87	Spring Retainer, 2 req'd.....
2	LT-1035	Arc Shield, Left Hand.....	37		10-24x1" R.I. Machine Screw and Lk. Washer
3	LT-1081	Arc Plate Connector, 2 req'd.....	38	EL-1-A	Control Circuit Arm, Complete, for Open or Closed Control Circuit.....
4		1/4"-20x2" H.I. Cap Screw, Nut and Shake-Proof Lk. Washer.....	39	EL-2-A	Control Circuit Arm, Complete for Open and Closed Control Circuit.....
5	ZO-1150	Cup Washer, 2 req'd.....	40	EL-47	Control Circuit Arm, Only.....
●6	22999-14400	Binding Screw.....	41	FP-24B13	Bearings, 2 req'd. Pressed into Magnet Arm....
●7	29418-14400	Binding Nut.....	†42	LT-1025-A	Assembled Connector.....
8	LT-1049	Arc Shield Hinge, 2 req'd.....	43	L-1013-A	Assembled Magnet Arm.....
9	LT-1050	Arc Shield Clip.....	44	LT-1443	Set Screw.....
10		1/4"-20x2" H.I. Cap Screw with 2 Nuts.....	45		1/4"-20 H.I. Nut.....
11		1/4" Std. 1 Washer and Lk. Washer.....	46	LT-2038	Auxiliary Arm Pin.....
12		Base, Advise Name Plate Data.....	47	FP-24B12	Bearing, 2 req'd. Pressed into Magnet Arm.....
13	LT-1039	Blowout Core.....	48	L-1021	Spring Bracket.....
14	LT-1074	Blowout Core Insulator.....	†49	L-1027	Contact Spring.....
15	L-1730-A	Assembled Blowout Coil and Contact Bracket	50	LT-1028-A	Assembled Auxiliary Arm.....
16	LT-1075	Blowout Ear Insulator.....	51		1/4"-20x3/4" H.I. Cap Screw and Lk. Washer....
17		1/4"-20x1/2" H.I. Cap Screw and Lk. Washer....	52		1/4"-20x1/2" H.I. Cap Screw and Lk. Washer, 2 req'd.....
18	LT-1052	Blowout Ear, 2 req'd.....	●†53	AMMS-44-11	Contact Tip.....
19		10-24 H.I. Nut and Lk. Washer, 2 req'd.....	54		1/4"-20x3/4" Everdur Hex. Machine Bolt and Lk. Washer.....
20	L-1721	Coil Terminal Stud.....	55	L-1015-A	Assembled Core.....
21		10-24x3/4" R. Stl. Machine Screw.....	56	L-1026	Core Cap.....
22	L-1018-A	Frame.....	†57	L-1011-AE	Operating Coil, 115 Volt.....
●*23	L-1705-A	Blowout Connector.....	†58	L-1010-AE	Operating Coil, 230 Volt.....
24	LT-1029-A	Magnet Arm Bracket.....	59		1/4"-20x3/4" H.I. Cap Screw and Lk. Washer....
25	LT-1443	Set Screw.....	●†60	AMMS-44-11	Contact Tip.....
26		1/4"-20 H.I. Nut.....	61	LT-1064	Blowout Ear Spacer.....
27	EL-120	Mounting Stud, 2 req'd.....	62	LT-1072	Stud, For Blowout Ear Spacer.....
28	LT-1037	Magnet Arm Pin.....	63	LT-1265-A	Blowout Guard.....
†29	EL-109-A	Assembled Contact.....	64		8-32x3/4" F.I. Machine Screw, (not shown) 2 req'd.....
30		10-32x3/4" R. Stl. Machine Screw and Lk. Washer.....	65	ZO-1121	Cup Washer, (not shown) 2 req'd.....
31	FP-28H1-10	Terminal.....	66	LT-1036	Arc Shield, Right Hand.....
32	EL-100-A	Control Circuit Base.....	67	LT-1032	Arc Plate.....
33	L-1709	Terminal Bracket.....			
†34	EL-84-A	Assembled Contact Bridge, 1 req'd. for Item 38, 2 req'd. for Item 39.....			
†35	EL-49	Spring.....			

MECHANICALLY-TIED CONTACTORS

Two or more single pole contactors, mounted on a single base, may be mechanically tied to operate as a multiple-pole contactor.

For this type contactor, the following parts are used.

Item No.	List No.	Description
12		Base, Advise Name Plate Data.....
68	L-1036	Tie Bar.....
69	L-1034	Tie Bar Spacer.....
70		1/4"-20x3/4" H. Stl. Slotted Hd. Machine Screw, Blk. Burr and Lk. Washer.....
71	L-1083-A	Assembled Magnet Arm.....
†72		Operating Coil, Advise Voltage and Number of Poles.....

† Essential Parts for General Maintenance.

* Early production of contactors had blowout connector mounted on front of base as illustrated. Current production has blowout connector mounted on rear of base.

● Minor revision since previous issue.

NEMA SIZE 3 SINGLE POLE L LINE-ARC CONTACTOR, FOLIO 3A

MECHANICAL INTERLOCKS: These are horizontal bakelite bars, pivoted at the center. They are carefully ground at the factory to suit the contactors with which they are used. They must prevent the contacts of both contactors touching simultaneously but not interfere with the complete closure and seal of either contactor alone. **CAUTION**—The interlock should maintain one set of contacts open at least $\frac{3}{8}$ " when the other contacts just touch.

MAIN CONTACTS: These are made of pure copper by a special forging process to give high Brinell hardness throughout their entire thickness. These contacts close with a slight rolling action, there is no wiping action.

The stationary and moving contacts may wear unequally, depending upon polarity. It may not be necessary to change both contact tips when replacement is necessary. The best operation is obtained with positive connection to the stationary contact and negative to the moving contact. Wiring diagrams are so arranged by the Square D Company.

CONTACT-WEAR ALLOWANCE: In the table at right is shown the correct dimension for auxiliary arm opening. Contact follow-up is necessary so that the contact pressure will be maintained as the contacts wear. The follow-up is the amount of opening between the moving contact auxiliary arm and its stop shown at "B" in the sketch below, **WITH THE CONTACTOR FULLY CLOSED.** Follow-up decreases with contact wear. When dimension "B" is reduced to $\frac{1}{32}$ ", the contact tips must be replaced.

MAIN CONTACT PRESSURE: Type L contactors are designed with contact pressures as given in the table below. A slight arcing or spitting of the contacts when closing may be an indication that the contact tips or spring should be replaced.

To check spring pressures, a spring balance may be used with a tape on the hook passing around the contact tip at its point of contact and pulled at right angles to the auxiliary contact arm, as shown in the sketch below. Contact pressure is correct if the balance scale shows a pull as given in the following table with the arm just leaving its stop at "B".

OPENING WHEN NEW	
Opening at "B" with Contactor fully closed.....	220"
CONTACT PRESSURE IN POUNDS	
Surfaces at "B" just breaking (new or old).....	2.0-2.5
Sealed, Contactor fully closed (when new)	4.0-4.5

