

(NEMA SIZE 3)

No. 1 DOUBLE POLE L LINE-ARC CONTACTOR

FOLIO 3

FOR DC OPERATION

INSTRUCTIONS

TYPE L LINE-ARC CONTACTORS are general purpose, direct current magnetic contactors.

Contactor Size		Continuous Rating Amperes	Crane and Mill Rating Amperes	Rupturing Capacity Amperes
NEMA	EC&M			
No. 3	No. 1	100	133	1000

LINE-ARC: These contactors derive their name from the manner in which they handle the arc. The Line-Arc principle of controlling the arc is simple . . . and automatic. There is nothing to adjust or wear out. At the instant the contacts start to separate, the arc is automatically transferred from the contacts to the arcing plate and circular guard over the blowout coil. The arc, as it travels along the arcing plate and circular guard, is stretched out in a line centered between the arc shields. Hence—cool contacts and the name Line-Arc.

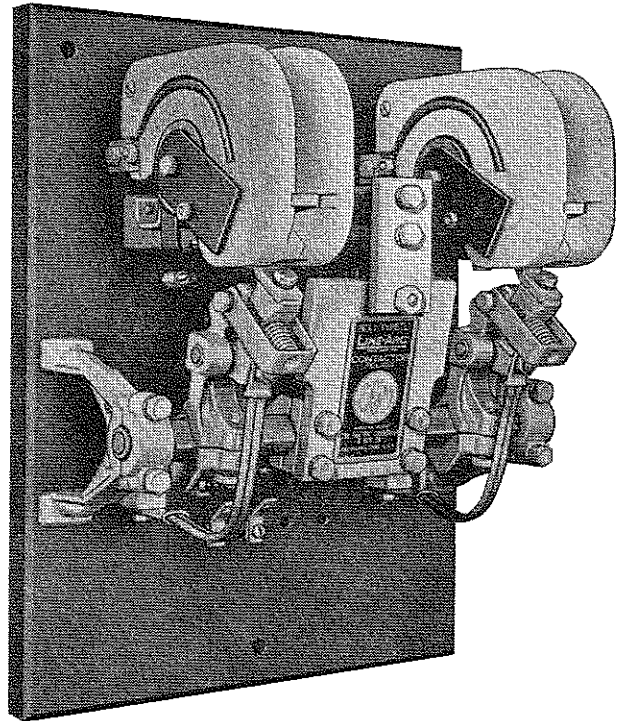
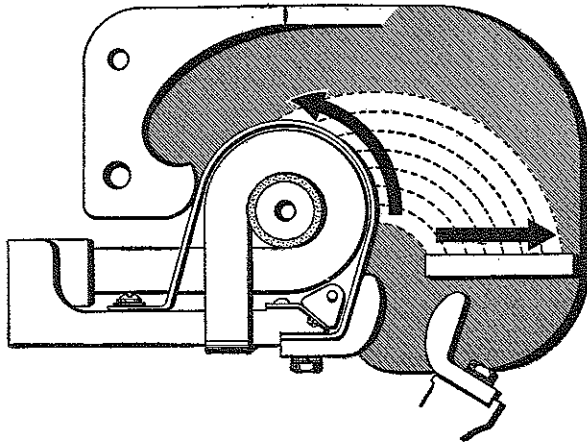

CAUTION — Before operating the contactor under load, be sure that the arc shields are lowered in their proper positions.

INSTALLATION: Mount the contactors vertically on rigid supports with at least 3" clearance above and in front of the arc shields to provide the proper distance for arcing clearance and also for removal of the arc shields. The life of the contactor will be considerably prolonged by installing it in a clean, dry place, preferably in a cabinet and as free as possible from external vibration or shock.

MAGNET AIR GAP: To insure quick release of the magnet arm, an air gap of .034" minimum and .049" maximum is provided between the magnet armature and the front ends of the U-shaped frame. See that the magnet faces are free from oil or sticky foreign material.

BEARINGS: Type L contactors are equipped with Nitralloy pins and Oilite bearings. These bearings are self-lubricating and require no lubrication in the field.

OPERATING COILS: These contactors will operate satisfactorily on 80% of normal control voltage when the coils are hot and will hold in on 20% of normal voltage. The coils will stand 110% of normal voltage continuously.

Contactors for 115 and 230 volt service are supplied with continuous capacity coils. Contactors for 550 volt service are supplied with a 230 volt coil and suitable resistor mounted on the back of the base.

To remove the operating coil, first remove the control circuit arm and then remove the stop plate. The magnet armature may now be lowered to remove the operating coil.

ELECTRICAL INTERLOCKS: These consist of stationary contacts mounted on the base and a moving contact attached to the magnet arm clamp. The moving contact should provide 1/8" follow-up when the magnet arm reaches its limit of travel, either completely closed or completely opened. The rating of these electrical interlocks is as follows:

	Max. Inrush	Cont. Amps.	Rupturing Capacity Amps. Inductive			
			115 V.	250 V.	440 V.	550 V.
A.C.	30	15	10	10	5	5
D.C.	30	15	2.5	1.0	.4	.4

(Continued on Page 4)

SQUARE D COMPANY Cleveland, Ohio 44128

SUPERSEDES CATALOG 11-1312

No. 1 DOUBLE POLE L LINE-ARC CONTACTOR, FOLIO 3

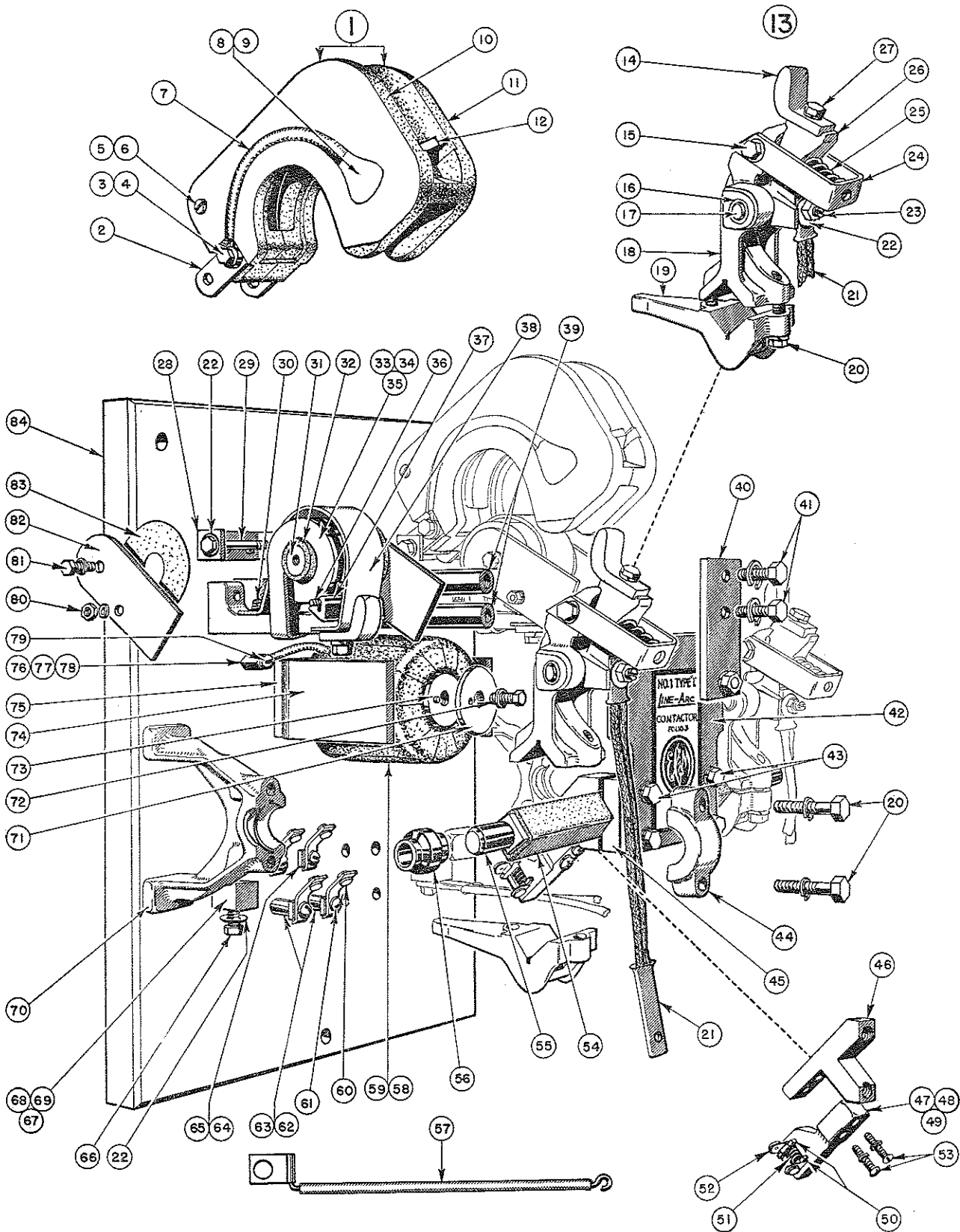

No. 1 DOUBLE POLE L LINE-ARC CONTACTOR, FOLIO 3

NOTE: Indented items are component parts
of item immediately preceding.

Item No.	List No.	Description	Item No.	List No.	Description
1	LT-1024-A	Assembled Arc Shield, 2 req'd	44	LT-1125	Bearing Bracket Clamp, 2 req'd.
2	LT-1049	Arc Shield Hinge, 2 req'd.	45	⊙ L-1211	Clamp, 2 req'd.
3		¼"-20x2" H.I. Cap Screw, Nut & Shakeproof Lk. Washer	46	⊙ L-1206	Magnet Arm Clamp, 2 req'd.
4	ZO-1150	Cup Washer, 2 req'd.	47	⊙ EL-1-A	Control Circuit Arm, Complete, for Open or Closed Control Circuit
5	FP-23A36	Binding Screw	48	⊙ EL-2-A	Control Circuit Arm, Complete, for Open and Closed Control Circuit
6	FP-23A13	Binding Nut	49	⊙ EL-47	Control Circuit Arm only
7	LT-1081	Arc Plate Connector, 2 req'd.	50	⊙ EL-87	Spring Retainer, 2 req'd.
8		8-32x¾" F.I. Mch. Screw, (not shown) 2 req'd.	†51	⊙ EL-49	Spring
9	ZO-1121	Cup Washer, (not shown) 2 req'd.	†52	⊙ EL-84-A	Contact Bridge, 1 req'd. for Item 47, 2 for Item 48
10	LT-1035	Arc Shield, left hand	53		10-24x1" R.I. Mch. Screw & Lk. Washer, 2 req'd.
11	LT-1036	Arc Shield, right hand	54	LT-2614	Shaft Insulator, 2 req'd. (Double Pole only)
12	LT-1032	Arc Plate	55	⊙ L-1208-A	Shaft, complete with Insulator Item 54 (Double Pole only)
13	⊙ L-1203-G	Assembled Contact Arm, complete, 2 req'd.	56	LT-1121	Oilite Bearing, 2 req'd.
†14	LT-1031	Contact Tip	57	LT-1128-A	Blowout Connector
15		¼"-20x½" H.I. Cap Screw & Lk. Washer, 2 req'd.	†58	⊙ L-2010-AE	Coil, for 230 Volt Double Pole only
16	FP-24B12	Oilite Bearing, 2 req'd. per Contact Arm	†59	⊙ L-2011-A	Coil, for 115 Volt Double Pole only
17	LT-2038	Auxiliary Arm Pin			NOTE: When ordering Coils, specify voltage and number of Poles.
18	⊙ L-1204-A	Contact Arm, complete with Bearing Item 16	†60	⊙ EL-6-A	Contact, 2 req'd. for Open or Closed Control Circuit, 4 req'd for Open and Closed Control Circuit
19	LT-1123	Contact Arm Clamp	61		10-24x½" R.I. Mch. Screw & Lk. Washer
20		⅝"-18x1¼" H.I. Cap Screw & Lk. Washer, 2 req'd.	62	⊙ EL-13	Stud, for 1"-1¼" Base (list number stamped on Stud)
†21	LT-1114-A	Connector	63	⊙ EL-14	Stud, for 1½"-2" Base (list number stamped on Stud)
22		¼" Std. I. Washer & Lk. Washer	64	⊙ EL-7	Stud, for 1"-1¼" Base (list number stamped on Stud)
23	LT-1443	Set Screw & ¼" H.I. Nut	65	⊙ EL-8	Stud, for 1½"-2" Base (list number stamped on Stud)
24	⊙ L-1021	Spring Bracket	66		¼"-20x⅜" H.I. Cap Screw
†25	⊙ L-1027	Contact Spring	67	LT-1044-A	Main Terminal Stud, for 1" Base
26	LT-1028-A	Auxiliary Arm	68	LT-1045-A	Main Terminal Stud, for 1¼"-1½" Base
27		¼"-20x¾" H.I. Cap Screw & Lk. Washer	69	LT-1646-A	Main Terminal Stud, for 2" Base
28	LT-1050	Arc Shield Clip	70	LT-1115	Bearing Bracket
29		¼"-20x2" H.I. Cap Screw with 2 Nuts	71	⊙ L-1026	Core Cap
30		¼"-20x¾" R.I. Mch. Screw, ¼" Bik. Burr & Lk. Washer	72		¼"-20x¾" Bronze Hex. Mch. Bolt & Lk. Washer
31	LT-1039	Blowout Core	73	⊙ L-2015-A	Core
32	LT-1074	Insulator, for Blowout Core	74	⊙ L-2018-A	Magnet Frame
33	LT-1656-A	Blowout Coil & Contact Bracket, for 1" Base	75	⊙ L-1213-A	Spacer
34	LT-1657-A	Blowout Coil & Contact Bracket, for 1¼"-1½" Base	76	LTZ-1809	Coil Terminal Stud, for 1" Base
35	LT-1658-AB	Blowout Coil & Contact Bracket, for 2" Base	77	LTZ-1810	Coil Terminal Stud, for 1¼"-1½" Base
36	LT-1072	Stud, for Blowout Ear Spacer	78	LTZ-1811	Coil Terminal Stud, for 2" Base
37	LT-1064	Blowout Ear Spacer	79		10-24x⅜" R.I. Mch. Screw & Lk. Washer
38	LT-1265-A	Blowout Guard	80		10-24 H.I. Nut & Lk. Washer, for Blowout Ear Spacer Stud
39	⊙ L-1219	Stop Bar, 2 req'd.	81		¼"-20x½" H.I. Cap Screw & Lk. Washer
40	⊙ L-1214-A	Stop Plate (Includes Spl. Cap Screw LTZ-1304, ⅝" H. I. Jam Nut & Lk Washer)	82	LT-1052	Blowout Ear
41		⅝"-18x¾" H.I. Cap Screw & Lk. Washer, 2 req'd.	83	LT-1075	Insulator, for Blowout Ear
42	⊙ L-1210	Armature Plate	84		Base, specify thickness and number of Poles
43		⅝"-18x1½" H.I. Cap Screw & Lk. Washer, 4 req'd.			

†Essential Parts for General Maintenance.

⊙These are new parts used on Folio 3 Contactors and are not interchangeable with parts of previous design contactors. All other parts are interchangeable.

No. 1 DOUBLE POLE L LINE-ARC CONTACTOR, FOLIO 3

MECHANICAL INTERLOCKS: These are horizontal bakelite bars, pivoted at the center. They are carefully ground at the factory to suit the contactors with which they are used. They must prevent the contacts of both contactors touching simultaneously but not interfere with the complete closure and seal of either contactor alone. **CAUTION** — The interlock should maintain one set of contacts open at least $\frac{3}{16}$ " when the other contacts just touch.

MAIN CONTACTS: These are made of pure copper by a special forging process to give high Brinell hardness throughout their entire thickness. These contacts close with a slight rolling action, there is no wiping action. Contactors are adjusted at the factory for simultaneous closing of the contacts.

The stationary and moving contacts may wear unequally, depending upon polarity. It may not be necessary to change both contact tips when replacement is necessary. The best operation is obtained with positive connected to the stationary contacts and negative to the moving contacts. Wiring diagrams are so arranged by the EC&M Company.

MAIN CONTACT OPENING: In the table at right are the correct dimensions for contact opening, and the contact pressure, both initial and when the contactor is sealed. Contact follow-up is necessary so that the contact pressure will be maintained as the contacts wear. The follow-up is the amount of opening between the moving contact auxiliary arm and its stop shown at "B" in the sketch below, WITH THE CONTACTOR FULLY CLOSED. Follow-up decreases with contact wear. When dimension "B" is reduced to $\frac{1}{32}$ ", the contacts must be replaced.

MAIN CONTACT PRESSURE: Type L contactors are designed with contact pressures as given in the table below. A slight arcing or spitting of the contacts when closing may be an indication that the contact tips or springs should be replaced.

To check spring pressures, a spring balance may be used with a tape on the hook passing around the contact tip at its point of contact and pulled at right angles to the auxiliary contact arm, as shown in the sketch below. Contact pressure is correct if the balance scale shows a pull as given in the following table with the arm just leaving its stop at "B".

OPENING WHEN NEW	
Opening at "B" with Contactor fully closed220"
CONTACT PRESSURE IN POUNDS	
Surfaces at "B" just breaking (new or old)	2.0-2.5
Sealed, Contactor fully closed (when new)	4.0-4.5

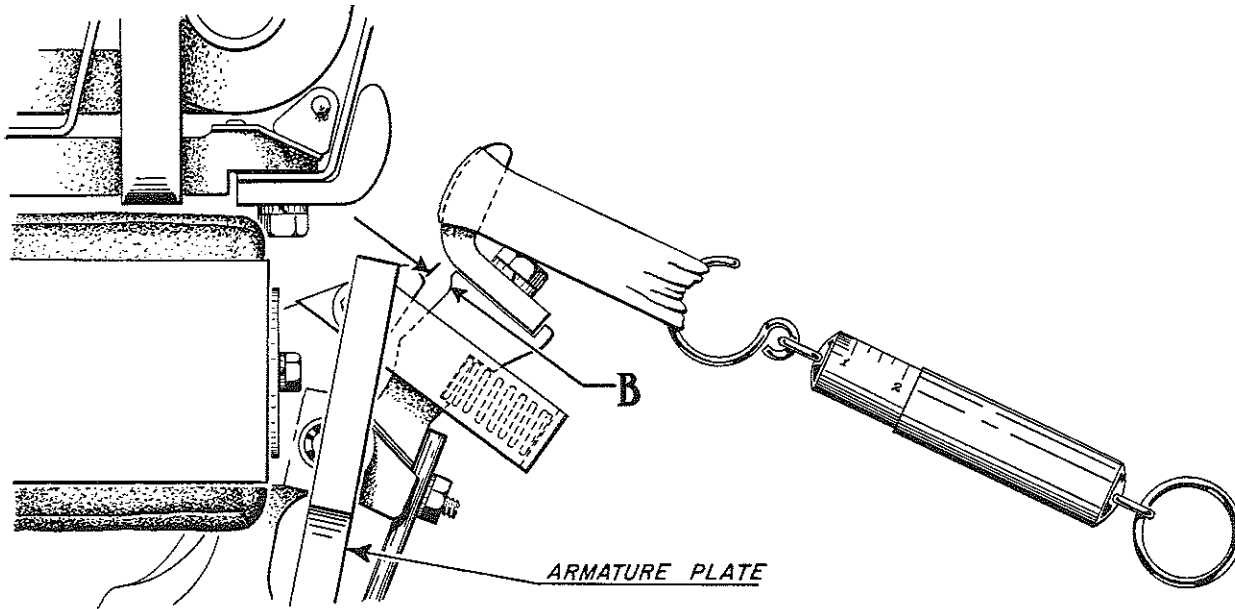

PRINTED IN U. S. A. 11-56