

No. 6 SINGLE POLE L LINE-ARC CONTACTOR FOLIO 3 FOR DC OPERATION

INSTRUCTIONS

TYPE LINE-ARC CONTACTORS are general purpose, direct current magnetic contactors.

Contactor Size		Continuous Rating Amperes	Crane and Mill Rating Amperes
NEMA	EC&M		
No. 8	No. 6	1350	1800

LINE-ARC: These contactors derive their name from the manner in which they handle the arc. The Line-Arc principle of controlling the arc is simple... and automatic. There is nothing to adjust or wear out. At the instant the contacts start to separate, the arc is automatically transferred from the contacts to the arcing plate and circular guard over the blowout coil. The arc, as it travels along the arcing plate and circular guard, is stretched out in a line centered between the arc shields. Hence—cool contacts and the name Line-Arc.

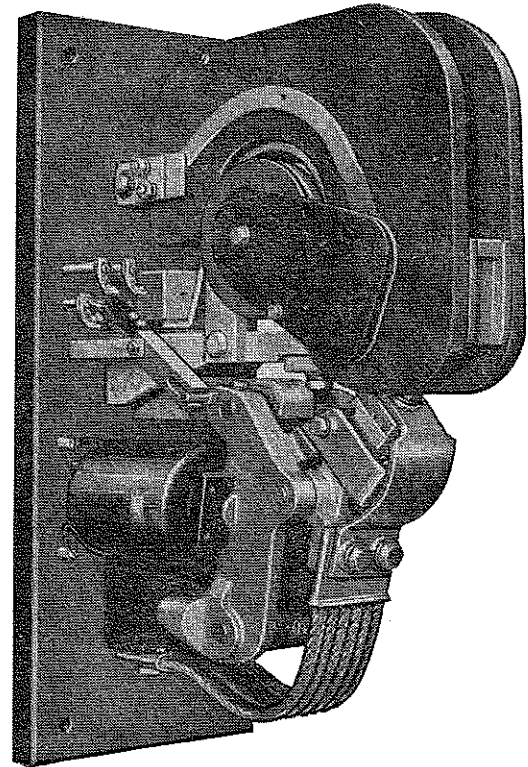
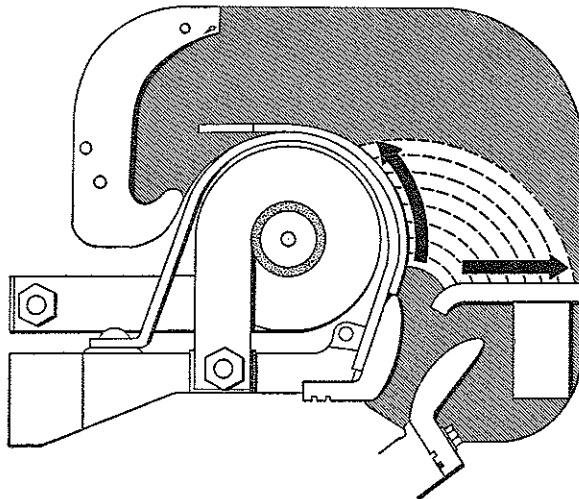

This contactor has a horseshoe type magnetic circuit using duplicate magnet coils connected in series.

Contactors for 115 and 230 volt service are supplied with two half-voltage coils. Contactors for 550 volt service are supplied with two 230 volt coils and suitable resistor mounted on the base.

To remove the operating coils, first back out the magnet arm pin set-screw and remove the magnet arm pin. The magnet arm may then be lowered to remove the operating coils.

ELECTRICAL INTERLOCKS: These consist of stationary contacts mounted on the base and a moving contact operated by a pin on the top of the magnet arm. The moving contact should provide 1/8" follow-up when the magnet arm reaches its limit of travel, either completely closed or completely opened. The rating of these electrical interlocks is as follows:

	Max. Inrush	Cont. Amps.	Rupturing Capacity Amps. Inductive			
			115 V.	250 V.	440 V.	550 V.
A.C.	30	15	10	10	5	5
D.C.	30	15	2.5	1.0	.4	.4

CAUTION—Before operating the contactor under load, be sure that the arc shield is lowered in its proper position.

INSTALLATION: Mount the contactors vertically on rigid supports with at least 3 1/2" clearance above and in front of the arc shields to provide the proper distance for arcing clearance and also for removal of the arc shields. The life of the contactor will be considerably prolonged by installing it in a clean, dry place, preferably in a cabinet and as free as possible from external vibration or shock.

MAGNET AIR GAP: To insure quick release of the magnet arm, a non-magnetic spacer .045" thick is placed between the magnet cores and the core caps. See that the magnet faces are free from oil or sticky foreign material.

BEARINGS: Type L contactors are equipped with hardened steel alloy pins and Oilite bearings. These bearings are self-lubricating and require no lubrication in the field.

OPERATING COILS: These contactors will operate satisfactorily on 80% of normal control voltage when the coils are hot and will hold in on 20% of normal voltage. The coils will stand 110% of normal voltage continuously.

(Continued on Page 4)

NO. 6 SINGLE POLE L LINE-ARC CONTACTOR, FOLIO 3

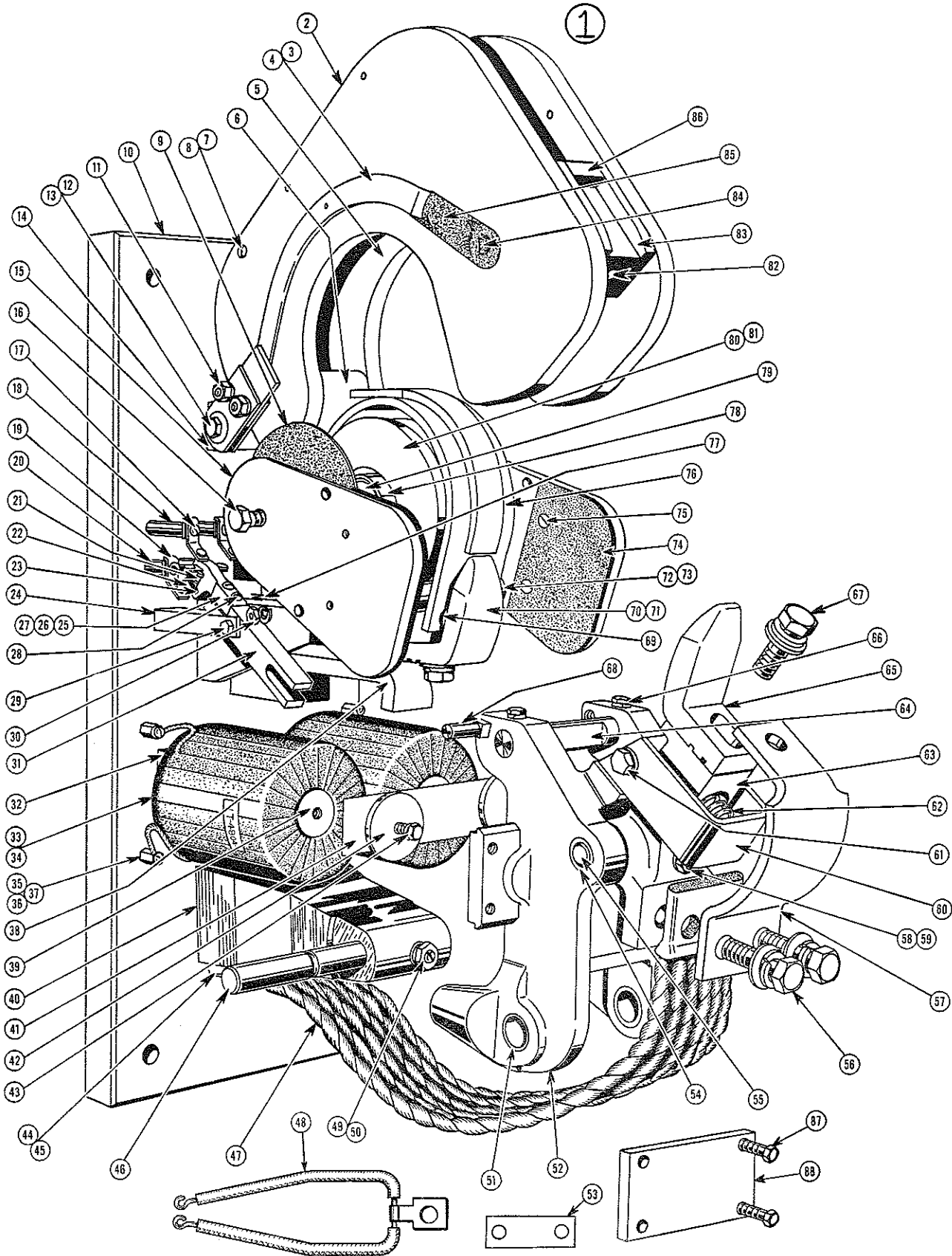

ADVISE NAMEPLATE DATA WHEN ORDERING PARTS

NO. 6 SINGLE POLE L LINE-ARC CONTACTOR, FOLIO 3

Item No.	List No.	Description	Item No.	List No.	Description
1	L-6003-A	Assembled Arc Shield, Complete.....	46	L-6055	Magnet Arm Pin.....
2	L-6041	Arc Shield, Left Hand.....	†47	L-6015-A	Assembled Connector.....
3	L-6045-A	Arc Plate Connector, Left Hand.....	48	L-6054-A	Blowout Connector.....
4	L-6046-A	Arc Plate Connector, Right Hand (Not Shown).....	49	L-6057	Set Screw.....
5	L-6042	Arc Shield, Right Hand.....	50		3/8"-16 H.I. Jam Nut and Lk. Washer.....
6	L-6026	Arc Shield Spacer.....	51	FP-24B16	Bearing, 2 req'd. Pressed into Magnet Arm.....
7	FP-23A14	Binding Post.....	52	L-6013-A	Assembled Magnet Arm.....
8	FP-23A36	Binding Screw.....	53	L-6066	Connector, Used Between Hinge Studs.....
9	L-6064	Blowout Ear Insulator, 2 req'd.....	54	FP-24B15	Bearing, 2 req'd. Pressed into Magnet Arm.....
10		Base, Advise Name Plate Data.....	55	L-6056	Auxiliary Arm Pin.....
11		5/16"-18x4 1/2" H.I. Cap Screw, Lk Washer and H.I. Nut.....	56		1/2"-13x1 1/2" H.I. Cap Screw, S.A.E. Aircraft Washer and Lk. Washer.....
12		3/8"-16x1" H.I. Mach. Screw and H.I. Nut.....	57	L-6052	Auxiliary Arm Shunt.....
⊙13	BS9302-004-03	Spring Washer.....	58	L-6058	Set Screw.....
14	L-6029-A	Assembled Arc Shield Clip.....	59		5/16"-18 H.I. Jam Nut and Lk. Washer.....
15	L-6040-A	Assembled Blowout Ear, 2 req'd.....	60	L-6022-A	Assembled Spring Bracket.....
16		3/8"-16x1" H.I. Cap Screw and Lk. Washer.....	61		3/8"-16x3/8" H.I. Cap Screw and Lk. Washer, 2 req'd.....
17		10-24x1/2" R.I. Screw and Lk. Washer.....	†62	L-6027	Contact Spring.....
18	EL-30	Stud.....	63	L-6049	Auxiliary Arm.....
†19	EL-6-A	Control Circuit Contact.....	64	L-6050	Stop Pin.....
20	EL-96	Stud.....	⊙†65	A50005-025-01	Contact Tip.....
†21	EL-49	Spring.....	66		1/4"-20x3/4" H.I. Cap Screw and Lk. Washer, 2 req'd.....
†22	EL-84-A	Assembled Contact Bridge, 1 req'd. For Item 25, 2 req'd. For Item 26.....	67		1/2"-13x1 3/4" H.I. Cap Screw, S.A.E. Aircraft Washer and Lk. Washer.....
23	EL-87	Spring Retainer, 2 req'd.....	68	EL-93	Operating Pin, Uses 3/8"-16 H.I. Jam Nut and Lk. Washer.....
24	EL-92-A	Assembled Arm Support.....	69		1/4"x1/2" Type "F" Binding HD. Self Tap. Screw, 2 req'd.....
25	EL-1-A	Control Circuit Arm, Complete, For Open or Closed Control Circuit.....	⊙†70	A50005-025-01	Contact Tip.....
26	EL-2-A	Control Circuit Arm, Complete, For Open and Closed Control Circuit.....	71		1/2"-13x1 1/2" H.I. Cap Screw and Lk. Washer.....
27	EL-47	Control Circuit Arm, Only.....	72	L-6048	Blowout Ear Spacer, 2 req'd.....
28		10-24x1 1/4" R.I. Screw, H.I. Nut, #6 Blk. Burr and 3/16" Lk. Washer.....	73	L-6065	Stud, For Blowout Ear Spacer.....
29	EL-95	Pivot Pin.....	74	L-6038	Insulator.....
30		1/4"-20 H.I. Nut and Lk. Washer.....	75		10x1/2" Type "F" Fl. HD. Self Tap Screw, 2 req'd.....
31	EL-94	Operating Arm.....	76	L-6020-A	Assembled Blowout Guard.....
32	LT-4814-A	Assembled Frame.....	77	L-6080	Blowout Guard Insulator, 2 req'd.....
⊙†33	LT-4805-AE	Operating Coil, For 115 Volt.....	78	L-6062	Blowout Core Insulator.....
⊙†34	LT-4804-AE	Operating Coil, For 230 Volt.....	79	L-6063	Blowout Core.....
35	LTZ-1810	Coil Terminal Stud, 4 req'd. For 1 1/2" Base.....	80	L-6010-A	Assembled Blowout Coil and Contact Bracket, For 1 1/2" Base.....
36	LTZ-1811	Coil Terminal Stud, 4 req'd. For 2" Base.....	81	L-6011-A	Assembled Blowout Coil and Contact Bracket, For 2" Base.....
37		10-24x3/8" R.I. Mach. Screw.....	82		1/4"-20x2 1/2" R.B. Mach. Screw and #1114 Shakeproof Lk. Washer.....
38	L-6061-A	Assembled Stop.....	83	L-6009	Arc Block.....
39	L-4132-A	Assembled Core, 2 req'd.....	84		3/8"-16x1" F.I. Mach. Screw, 2 req'd. (Not Shown).....
40	L-6047	Magnet Arm Bracket.....	85		6-32x1/4" Flat HD. Type "F" Self Tapping Screw, 2 req'd. (Not Shown).....
41	LT-6003	Non-Magnetic Spacer.....	86	L-6018-A	Assembled Arc Plate.....
42	L-6094	Core Cap, 2 req'd.....			
43		1/4"-20x3/4" Everdur Hex. Mach. Bolt and Lk. Washer.....			
44	L-6075-A	Main Terminal Stud, (Not Shown) For 1 1/2" Base.....			
45	L-6076-A	Main Terminal Stud, (Not Shown) For 2" Base.....			

MECHANICALLY-TIED CONTACTORS

Two or more single pole contactors, mounted on a single base, may be mechanically tied to operate as a multiple-pole contactor.

For this type contactor, the following parts are used.

Item No.	List No.	Description
	10	Base, Advise Name Plate Data.....
†33		Operating Coil, Advise Name Plate Data.....
87		1/4"-20x3/4" Hex. Stl. Slotted HD. Machine Screw, Blk. Burr and Lk. Washer.....
88	L-4148	Tie Bar.....

†Essential Parts for General Maintenance.

⊙ Minor revision since previous issue.

NO. 6 SINGLE POLE L LINE-ARC CONTACTOR, FOLIO 3

MECHANICAL INTERLOCKS: These are horizontal bakelite bars, pivoted at the center. They are carefully ground at the factory to suit the contactors with which they are used. They must prevent the contacts of both contactors touching simultaneously but not interfere with the complete closure and seal of either contactor alone. **CAUTION**—The interlock should maintain one set of contacts open at least $\frac{3}{8}$ " when the other contacts just touch.

MAIN CONTACTS: These are made of pure copper by a special forging process to give high Brinell hardness throughout their entire thickness. These contacts close with a slight rolling action, there is no wiping action.

The stationary and moving contacts may wear unequally, depending upon polarity. It may not be necessary to change both contact tips when replacement is necessary. The best operation is obtained with positive connected to the stationary contacts and negative to the moving contact. Wiring diagrams are so arranged by the EC&M Division.

CONTACT-WEAR ALLOWANCE: In the table at right is shown the correct dimension for auxiliary arm opening. Contact follow-up is necessary so that the contact pressure will be maintained as the contacts wear. The follow-up is the amount of opening between the moving contact auxiliary arm and its stop shown at "B" in the sketch below. **WITH THE CONTACTOR FULLY CLOSED.** Follow-up decreases with contact wear. When dimension "B" reaches $\frac{1}{2}$ ", the contact tips must be replaced.

MAIN CONTACT PRESSURE: Type L contactors are designed with contact pressures as given in the table below. A slight arcing or splitting of the contacts when closing may be an indication that the contact tips or spring should be replaced.

To check spring pressures, a spring balance may be used with a tape on the hook passing around the contact tip at its point of contact and pulled at right angles to the auxiliary contact arm, as shown in the sketch below. Contact pressure is correct if the balance scale shows a pull as given in the following table with the arm just leaving its stop at "B".

OPENINGS WHEN NEW	
Opening at "B" with Contactor fully closed	250"
CONTACT PRESSURE IN POUNDS	
Surfaces at "B" just breaking (new or old).....	12.5-14
Sealed, Contactor fully closed (when new).....	23-24.5

