



TYPE HCO-1, SERIES A, NEMA SIZE 1, 25 AMPERE, DC CONTACTOR SINGLE POLE, NORMALLY OPEN

INSTALLATION AND ADJUSTMENT

Mount the contactor vertically on a rigid support. Provide at least .6" clearance above the top of the contactor base and 1.7" in front of the arc chute for arcing clearance and arc chute removal.

With the contactor power OFF, lift straight up on the arc chute (1) and remove it from the contactor. Operate the contactor by hand to see that the contact tips meet squarely. If they do not, adjust by the procedure described below in step 9 of "Contact Tip Replacement". When released, the contactor should open freely. If it does not, check for clearance around the bearing bracket (15) and the opening spring (31). Check all electrical connections to see that they are tight and replace the arc chute. No further adjustments are necessary.

CAUTION: Do not operate the contactor under load without the arc chute installed in its proper position.

TROUBLESHOOTING

PROBLEM: Contactor will not close when energized.

SOLUTION: Check the voltage at the operating coil terminals. An absence of voltage indicates a fault elsewhere in the circuitry. If the coil voltage is normal, disconnect the coil leads and check the coil for continuity. An open or shorted coil must be replaced.

REPAIR and MAINTENANCE

CONTACT TIP REPLACEMENT

To determine when the contact tips should be replaced, the contact follow up must be measured. The contact follow up is the distance "F" measured at the upper edge of the contact arm with the contactor fully closed, as shown on the right. When this distance is reduced to 1/32" or less, the contact tips must be replaced to assure that proper contact pressure is maintained.

Should it be necessary to replace the tips, a screwdriver is the only tool needed and the following procedure should be followed:

1. Lift straight up on the arc chute (1) and remove it from the contactor.
2. Unscrew the arc horn assembly (43), and remove the flexible connector and movable contact tip.
3. While pressing up on the flat spring (22), push the contact arm pin (23) out.
4. Remove the contact arm assembly and unscrew the screw (41) holding the stationary contact tip in place.
5. Install the new stationary contact tip (39), screw (41)*, and lock washer (40)*.
6. Replace the contact arm assembly making sure that the opening spring (31) is seated properly over the head of screw 29.

7. While lifting up on the end of the flat spring (22), replace the contact arm pin (23).
8. Reassemble the new movable contact tip (42), flexible connector (24), and arc horn (43), in that order.
9. Operate the contactor by hand to see that the tips meet squarely. Contact tip alignment can be adjusted by loosening the tip retaining screws and shifting the tips. After the contacts are properly aligned, retighten the screws securely.
10. Replace the arc chute.

COIL REPLACEMENT

To replace the operating coil, a screwdriver is required and the following procedure should be followed:

1. Lift straight up on the arc chute (1) and remove it.
2. Remove the coil leads.
3. Remove the two hairpin clips (22) and push the contact arm pin (23) out.
4. Remove the contact arm assembly.
5. Unscrew the screw (29) on the top of the magnet core and remove the coil.
6. Install the new coil and replace the core cap (26), the core cap spacer (27), lock washer (28), and screw (29).

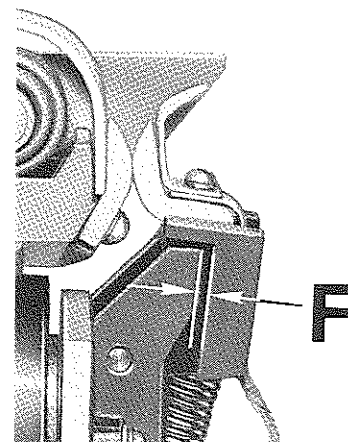
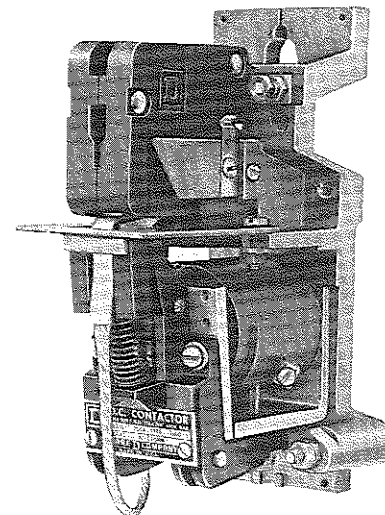

Make sure the core cap (heavy steel washer) is next to the coil.

7. Replace the contact arm assembly, making sure that the opening spring (31) is seated properly over the head of screw 29.
8. Replace the contact arm pin (23) and the two hairpin clips (22).
9. Reconnect the coil leads to the new coil and replace the arc chute.

LUBRICATION

The type "H" contactor requires no lubrication. The pivot pins bear in a self-lubricating material.

NOTE: *The special non-magnetic bolts and lockwashers supplied with the contact parts kit must be used.
•Minor revision since previous issue.



TYPE HCO-1, SERIES A, NEMA SIZE 1, 25 AMPERE, DC CONTACTOR, S.P., N.O.

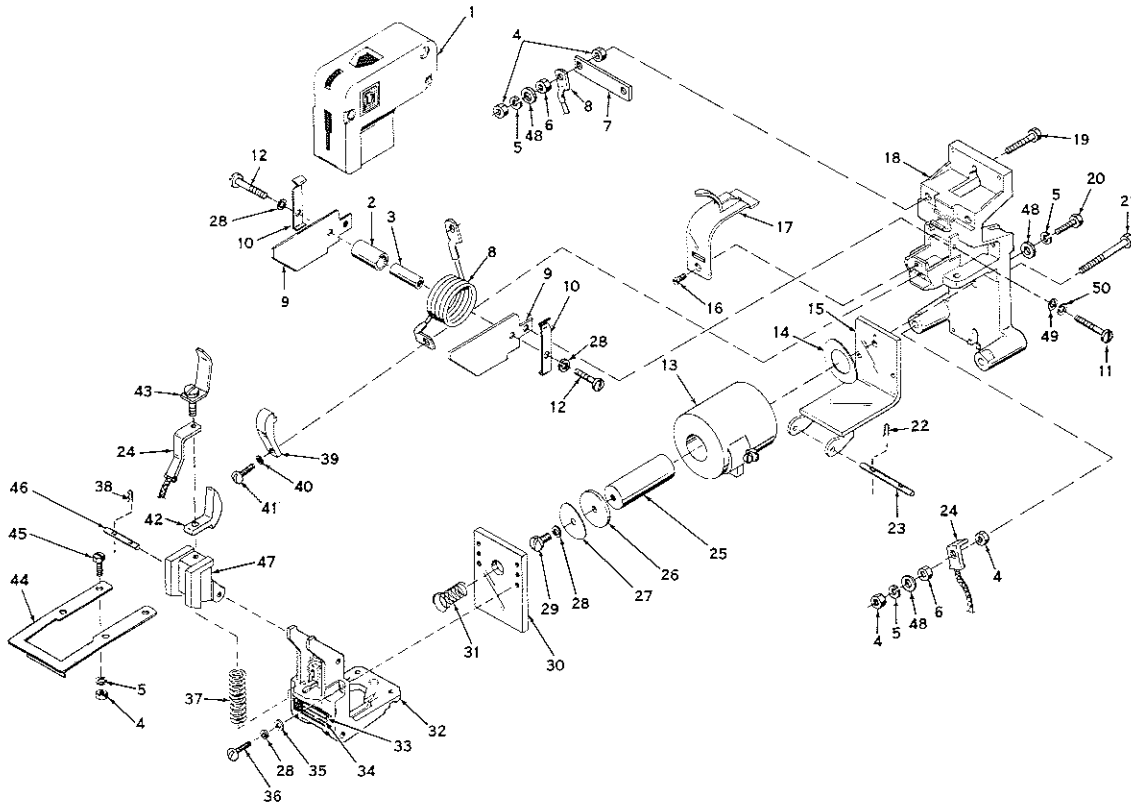

Item No.	Part No.	Description	Item No.	Part No.	Description	
* 1	A51015-035-50	Assembled Arc Chute	27	B50502-006-09	Core Cap Spacer	
2	B50512-052-29	Blowout Core Insulator	*28	23701-00160	#10 Lk. Washer, 5 Req'd.	
*3	B50502-776-06	Blowout Core	29	21507-16120	#10-24 x 3/8" Pan Hd. Stl. Screw	
*4	23003-00200	1/4"-20 Hex. Stl. Jam Nut, 8 Req'd.	30	A51015-043-01	Armature	
5	23701-00200	1/4" Lk. Washer, 5 Req'd.	31	B50502-602-07	Opening Spring	
6	23005-00202	1/4"-20 Hex. Brass Nut, Silver Dipped, 3 Req'd.	32	C51015-044-01	Contact Arm	
7	A51015-119-01	Terminal Tie Bar	33	A51139-093-01	Nameplate	
8	A51015-054-50	Assembled Blowout Coil	34	21509-12080	#6-32 x 1/4" Pan Hd. Type F Tapping Screws, 2 Req'd.	
9	A51015-032-01	Blowout Ear, 2 Req'd.	35	23601-00141	#10 Plain Washer, 2 Req'd.	
10	A51015-034-01	Arc Chute, Spring Clip, 2 Req'd.	36	21507-16200	#10-24 x 5/8" Pan Hd. Stl. Screw, 2 Req'd.	
*11	21590-14120	#8-32 x 3/8" Thd. Forming Screw, Pan Hd.	37	B50502-602-18	Auxiliary Arm Spring	
*12	21507-16160	#10-24 x 1/2" Pan Hd. Stl. Screw, 2 Req'd.	*38	A50502-701-03	Hairpin Clip (Aux. Arm Pin), 2 Req'd.	
*13	A51015-056-50	Assembled Operating Coil (240 V)				
	A51015-056-51	Assembled Operating Coil (120 V)				
14	A51017-041-01	Spring Washer	*39	Class 9998 Type HC-1 Kit (Copper)	Stationary Contact Tip #10 Lk. Washer, Silicon Bronze	
15	A51015-037-50	Assembled Magnet Frame	*40			#10-24-1/2" Rd. Hd. Silicon Bronze Screw
16	21201-12080	#6-32 x 1/4" Fl. Hd. Stl. Screw	*41			
17	A51015-033-01	Blowout Guard	*42	Type HC-2 Kit (Silver)	Movable Contact Tip	
18	C51015-028-50	Assembled Contactor Base	*43		Assembled Arc Horn	
19	21401-20310	1/4"-20 x 1" Hex. Hd. Stl. Screw, 2 Req'd.	44	A51015-053-01	Stop Plate	
20	21401-20280	1/4"-20 x 7/8" Hex. Hd. Stl. Screw	45	21408-20200	1/4"-20 x 5/8" Hex. Hd. Stl. Screw, 2 Req'd.	
21	21401-20560	1/4"-20 x 1-3/4" Hex. Hd. Stl. Screw, 2 Req'd.	*46	A51015-059-01	Auxiliary Arm Pin	
*22	A50502-701-01	Hairpin Clip (Contact Arm Pin), 2 Req'd.	47	B51015-045-50	Auxiliary Arm	
*23	A51015-061-01	Contact Arm Pin	48	23601-00200	1/4" Plain Washer, 3 Req'd.	
24	A51015-050-50	Assembled Connector	*49	23601-00121	#8 Plain Washer	
25	A51015-040-50	Assembled Coil Core	*50	23701-00140	#8 Lk. Washer	
26	B50502-006-08	Core Cap				

NOTE: Electrical and Mechanical Interlocks, Pneumatic Timers, and Tie Bars are listed under Class 9999 User Modification Kits. See Service Bulletin 9999-1

* Essential Parts for General Maintenance.

• Minor revision since previous issue.