



## TYPE HCO-2, SERIES A, NEMA SIZE 1, 25 AMPERE, DC CONTACTOR DOUBLE POLE, NORMALLY OPEN

### INSTALLATION AND ADJUSTMENT

Mount the contactor vertically on a rigid support. Provide at least .6" clearance above the top of the contactor base and 1.7" in front of the arc chute for arcing clearance and arc chute removal.

With the contactor power OFF, lift straight up on the arc chute (1) and remove it from the contactor. Operate the contactor by hand to see that the contact tips meet squarely. If they do not, adjust by the procedure described below in step 9 of "Contact Tip Replacement". When released, the contactor should open freely. If it does not, check for binding around the contact arm pin (23) or the opening spring (31). Check all electrical connections to see that they are tight. Now replace the arc chute. No further adjustments are necessary.

**CAUTION:** Do not operate the contactor under load without the arc chute installed in its proper position.

### TROUBLESHOOTING

**PROBLEM:** Contactor will not close when energized.

**SOLUTION:** Check the voltage at the operating coil terminals. An absence of voltage indicates a fault elsewhere in the circuitry. If the coil voltage is normal, disconnect the coil leads and check the coil for continuity. An open or shorted coil must be replaced.

### REPAIR and MAINTENANCE

#### CONTACT TIP REPLACEMENT

To determine when the contact tips should be replaced, the contact follow up must be measured. The contact follow up is the distance "F" measured at the upper edge of the contact arm with the contactor fully closed, as shown on the right. When this distance is reduced to 1/32" or less, the contact tips must be replaced to assure that proper contact pressure is maintained.

Should it be necessary to replace the tips, a screwdriver is the only tool needed and the following procedure should be followed:

1. Lift straight up on the arc chute (1) to remove it from the contactor.
2. Unscrew the arc horn assembly (43), and remove the flexible connector and movable contact tip.
3. Remove the two hairpin clips (22) and push the contact arm pin (23) out.
4. Remove the contact arm assembly and unscrew the screw (41) holding the stationary contact tip in place.
5. Install a new stationary contact tip (39), screw (41)\*, and lock washer (40)\*.
6. Replace the contact arm assembly making sure that the opening spring (31) is seated properly over the head of screw 29.

7. Replace the contact arm pin (23) and the two hairpin clips (22).
8. Reassemble the new movable contact tip (42), flexible connector (24), and arc horn (43), in that order.
9. Operate the contactor by hand to see that the tips meet squarely. Contact tip alignment can be adjusted by loosening the tip retaining screws and shifting the tips. After the contacts are properly aligned, retighten the screws securely.
10. Replace the arc chute.

#### COIL REPLACEMENT

To replace the operating coil, a screwdriver is required and the following procedure should be followed:

1. Lift straight up on the arc chute (1) and remove it.
2. Remove the coil leads.
3. Remove the two hairpin clips (22) and push the contact arm pin (23) out.
4. Remove the contact arm assembly.
5. Unscrew the screw (29) on the top of the magnet core and remove the coil.
6. Install the new coil and replace the core cap (26), the core cap spacer (27), lock

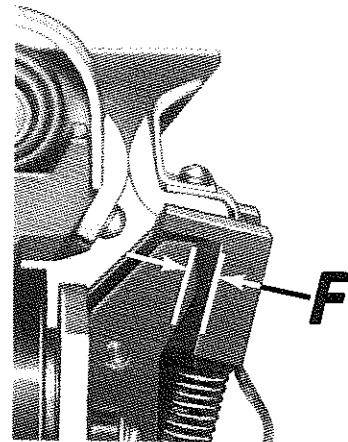
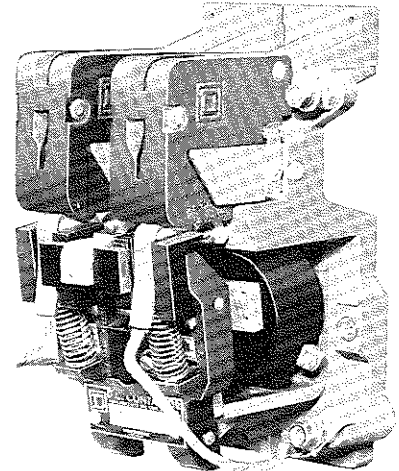

washer (28), and screw (29). Make sure the core cap (heavy steel washer) is next to the coil.

7. Replace the contact arm assembly, making sure that the opening spring (31) is seated properly over the head of screw 29.
8. Replace the contact arm pin (23) and the two hairpin clips (22).
9. Reconnect the coil leads to the new coil and replace the arc chute.

#### LUBRICATION

The type "H" contactor requires no lubrication. The pivot pins bear in a self-lubricating material.

**NOTE:** \*The special non-magnetic bolts and lockwashers supplied with the contact parts kit must be used.



TYPE HCO-2, SERIES A, NEMA SIZE 1, 25 AMPERE, DC CONTACTOR, D.P., N.O.

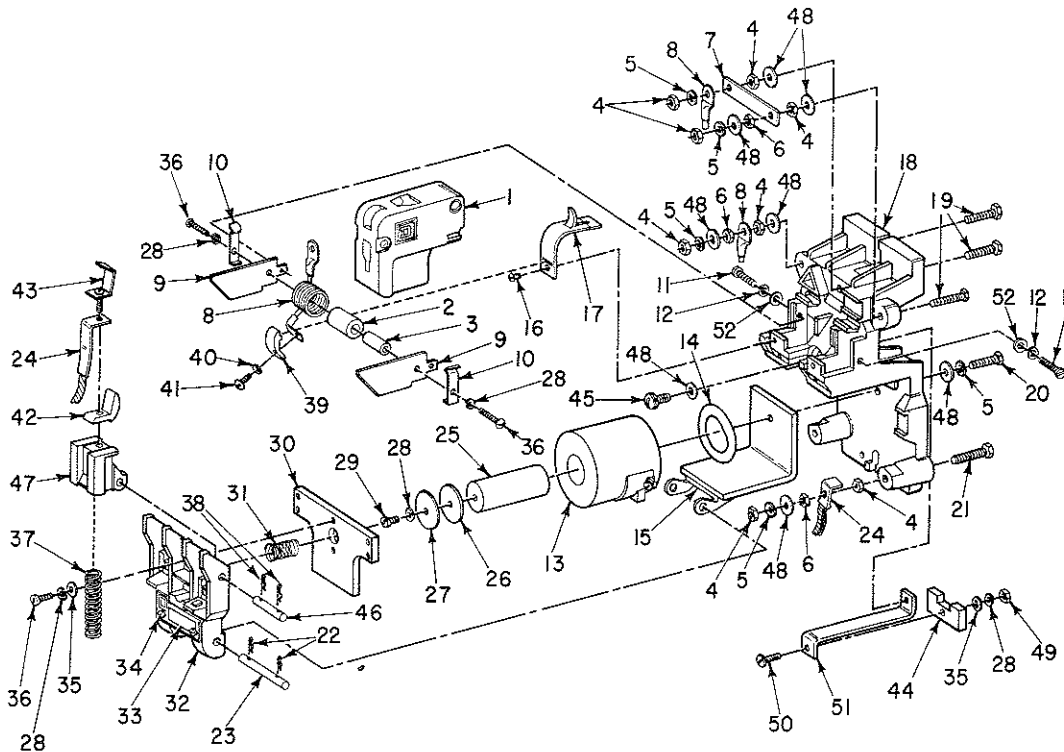

Item No.	Part No.	Description	Item No.	Part No.	Description
* 1	A51015-035-50	Assembled Arc Chute, 2 Req'd.	27	B50502-006-13	Core Cap Spacer
2	B50512-052-29	Blowout Core Insulator, 2 Req'd.	28	23701-00160	#10 Lk. Washer, 8 Req'd.
3	B50502-776-06	Blowout Core, 2 Req'd.	29	21507-16120	#10-24 x 3/8" Pan Hd. Stl. Screw
4	23003-00200	1/4"-20 Hex. Stl. Jam Nut, 10 Req'd.	30	A51015-176-01	Armature
5	23701-00200	1/4" Lk. Washer, 6 Req'd.	31	B50502-602-07	Opening Spring
6	23005-00202	1/4"-20 Hex. Brass Nut, Silver Dipped, 4 Req'd.	32	C51015-171-01	Contact Arm
7	A51015-119-01	Terminal Tie Bar	33	A51139-116-01	Nameplate
8	A51015-054-50	Assembled Blowout Coil, 2 Req'd.	34	21509-12080	#6-32 x 1/4" Pan Hd. Type F Tapping Screws, 2 Req'd.
9	A51015-032-01	Blowout Ear, 4 Req'd.	35	23601-00141	#10 Plain Washer, 3 Req'd.
10	A51015-034-01	Arc Chute, Spring Clip, 4 Req'd.	36	21507-16160	#10-24 x 1/2" Pan Hd. Stl. Screw, 6 Req'd.
11	21590-14120	#8-32 x 3/8" Hex. Pan Hd. Tri-Lobe Scr., 2 Req'd.	37	B50502-602-09	Auxiliary Arm Spring, 2 Req'd.
12	23701-00140	#8 Lk. Washer, 2 Req'd.	38	A50502-701-03	Hairpin Clip (Aux. Arm Pin), 4 Req'd.
*13	A51015-067-51	Assembled Operating Coil (240V)	*39	Class 9998	Stationary Contact Tip
	A51015-067-54	Assembled Operating Coil (120V)	*40	Type HC-1 Kit	#10 Lk. Washer, Silicon Bronze
14	A51017-041-01	Spring Washer	*41	(Copper)	#10-24-1/2" Rd. Hd. Silicon Bronze Screw
15	A51015-037-50	Assembled Magnet Frame	*42	Type HC-2 Kit	Movable Contact Tip
16	21201-12080	#6-32 x 1/4" Fl. Hd. Stl. Screw, 2 Req'd.	*43	(Silver)	Assembled Arc Horn
17	A51015-033-01	Blowout Guard, 2 Req'd.	44	A51015-173-01	Stop Plate
18	D51015-170-50	Assembled Contactor Base	45	A5-2927-026-50	1/4"-20 x 1/2" Pan Hd. Mch. Scr. Assem.
19	21401-20320	1/4"-20 x 1" Hex. Hd. Stl. Screw, 3 Req'd.	46	A51015-059-01	Auxiliary Arm Pin, 2 Req'd.
20	21401-20280	1/4"-20 x 7/8" Hex. Hd. Stl. Screw	47	B51015-045-50	Auxiliary Arm, 2 Req'd.
21	21401-20400	1/4"-20 x 1 1/4" Hex. Hd. Stl. Screw, 2 Req'd.	48	23601-00200	1/4" Plain Washer, 10 Req'd.
22	A50502-701-01	Hairpin Clip (Contact Arm Pin), 2 Req'd.	49	23001-00160	#10-24 Hex. Stl. Nut
23	A51015-061-01	Contact Arm Pin	50	21507-16240	#10-24 x 3/4" Pan Hd. Mch. Scr.
24	A51015-050-50	Assembled Connector, 2 Req'd.	51	A51015-172-01	Stop Plate Bracket
25	A51015-040-50	Assembled Coil Core	52	23601-00121	#8 Plain Washer, 2 Req'd.
26	B50502-006-12	Core Cap			

NOTE: Electrical and Mechanical Interlocks, Pneumatic Timers, and Tie Bars are listed under Class 9999 User Modification Kits. See Service Bulletin 9999-1

\* Essential Parts for General Maintenance.