



obsolete

TYPE HFO-1, SERIES B, NEMA SIZE 4, 150 AMPERE, DC CONTACTOR SINGLE POLE, NORMALLY OPEN

INSTALLATION AND ADJUSTMENT

Mount the contactor vertically on a rigid support. Provide at least 1" clearance above the top of the contactor base and 2" in front of the contactor for arcing clearance and arc chute removal.

- With the contactor power OFF, remove the arc chute (1) and operate the contactor by hand. The contact tips should meet squarely. If they do not, adjust by the procedure described below in step 6 of "Contact Tip Replacement". When released, the contactor should open freely. If it does not, check for the impaired operation of the contact arm assembly. Check all electrical connections to see that they are tight and replace the arc chute. No further adjustments are necessary.

CAUTION: Do not operate the contactor under load without the arc chute installed in its proper position.

TROUBLESHOOTING

PROBLEM: Contactor will not close when energized.

- **SOLUTION:** Check the voltage at the operating coil terminals. An absence of voltage indicates a fault elsewhere in the circuitry. If the coil voltage is normal, disconnect the coil leads and check the coil for proper resistance. Resistance values for standard coils are listed in the parts list on page 2. Resistance values for other coils are listed in the Class 9998 Magnet Coil Application Data sheet in the GIC catalog. An open or shorted coil must be replaced.

REPAIR and MAINTENANCE

CONTACT TIP REPLACEMENT

To determine when the contact tips should be replaced, the contact follow up must be measured. The contact follow up is the distance "F" measured at the upper edge of the contact arm with the contactor fully closed, as shown on the right. When this distance is reduced to 1/16" or less, the contact tips must be replaced to assure that proper contact pressure is maintained.

Should it be necessary to replace the tips, a 7/16" open end wrench is the only tool needed and the following procedure should be followed:

1. Remove the arc chute (1).
- 2. Unscrew the hex head bolt (38) holding the flexible connector and movable contact tip in place.
- 3. Remove these parts and unscrew the hex head bolt (38) holding the stationary contact tip in place.
- 4. Install a new stationary contact tip (36) and replace the bolt (38)*.
- 5. Reassemble the new movable contact tip (35) flexible con-

ductor (18), and bolt (38)* in that order.

6. Operate the contactor by hand to see that the tips meet squarely. Contact tip alignment can be adjusted by loosening the tip retaining bolts and shifting the tips. After the contacts are properly aligned, retighten the bolts securely.
7. Replace the arc chute.

COIL REPLACEMENT

To replace the operating coil, a screwdriver and a 7/16" open end wrench are needed and the following procedure should be followed:

1. Remove the arc chute.
2. Remove the coil leads.
3. Loosen the two pan head screws (20) and push the contact arm pin (19) out.
4. Remove the contact arm assembly.
5. Unscrew the hex head bolt (9) on the top of the magnet core and remove the coil.
6. Install the new coil and replace the core cap (23), the

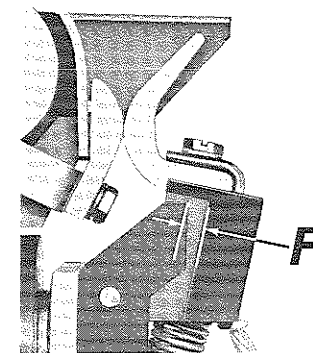
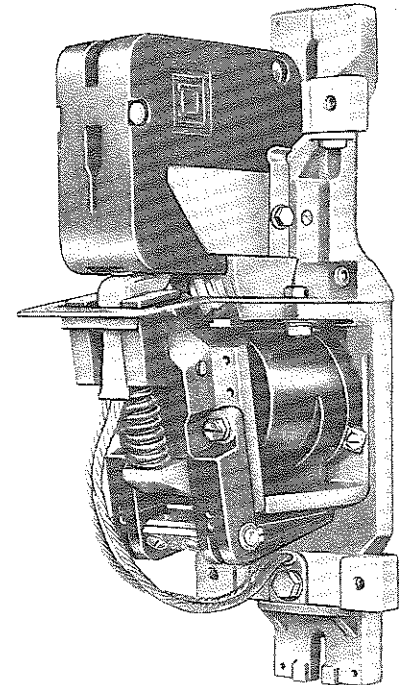

core cap spacer (22), lock-washer (8), and hex head bolt (9). Make sure the core cap (heavy steel washer) is next to the coil.

7. Replace the contactor arm assembly, contact arm pin (19) and tighten the two pan head screws (20).
8. Reconnect the coil leads to the coil and replace the arc chute.

LUBRICATION

The type "H" contactor requires no lubrication. The pivot pins bear in a self-lubricating material.

NOTE: *The special non-magnetic bolts and lockwashers supplied with the contact parts kit must be used.

•Minor revision since previous issue.

Supersedes SB 7004-51 Dated 3-71

PRINTED
IN
U.S.A.

SQUARE D COMPANY

P. O. Box 9247
Columbia, S.C. 29290

1.5M



TYPE HFO-1, SERIES B, NEMA SIZE 4, 150 AMPERE, DC CONTACTOR, S.P., N.O.

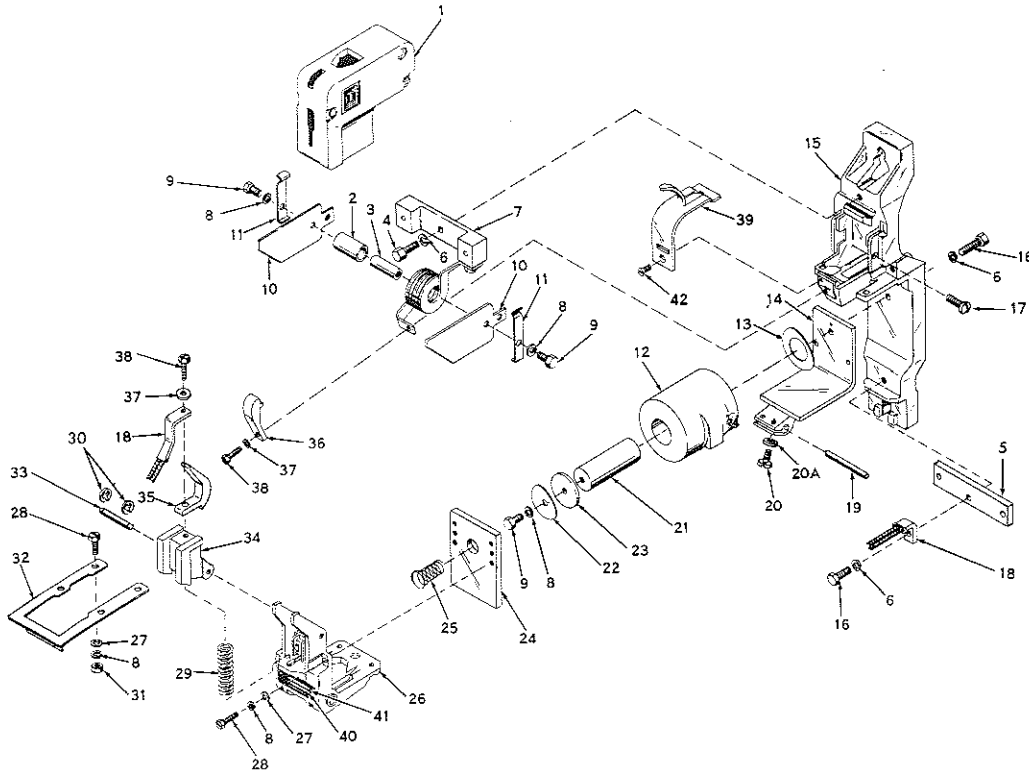

| Item No. | Part No. | Description | Item No. | Part No. | Description |
|----------|---------------|---|----------|-----------------------------|--|
| *1 | A51017-035-50 | Assembled Arc Chute | 20A | | #10 Plain Lock Washer |
| 2 | B50512-052-28 | Blowout Core Insulator | 21 | A51017-040-50 | Assembled Coil Core |
| ✓3 | B50502-776-14 | Blowout Core | 22 | B50502-006-06 | Core Cap Spacer |
| 4 | | 5/16" - 18 x 3/4" Hex Head Steel Cap Screw | 23 | B50502-006-05 | Core Cap |
| •5 | A51017-052-01 | Bottom Terminal Block | 24 | A51017-043-01 | Armature |
| •6 | | 3/16" Plain Lock Washer, 3 Req'd. | ✓25 | B50502-602-03 | Opening Spring |
| 7 | A51017-054-50 | Blowout Coil and Top Terminal Block Assembly | ✓26 | C51017-103-50 | Contact Arm Assembly with Bushings |
| •8 | | 1/4" Plain Lock Washer, 7 Req'd. | •27 | | 1/4" Plain Washer, 4 Req'd. |
| •9 | | 1/4" - 20 x 1/2" Hex Head Steel Cap Screw, 3 Req'd. | •28 | | 1/4" - 20 x 3/4" Slotted Hex Head Steel Cap Screw, 4 Req'd. |
| 10 | A51017-032-01 | Blowout Ear, 2 Req'd. | 29 | B50502-602-04 | Auxiliary Arm Spring |
| ✓11 | A51017-034-01 | Arc Shield Spring, 2 Req'd. | •30 | 29907-01610 | E - Rings, 2 Req'd. |
| ✓12 | A51017-056-50 | Assembled Operating Coil (240V Approximate Resistance 1619 ohms.) | •31 | | 1/4" - 20 Hex Steel Nut, 2 Req'd. |
| ✓ | A51017-056-51 | Assembled Operating Coil (120V Approximate Resistance 437 ohms.) | 32 | A51017-053-01 | Stop Plate |
| 13 | A51017-041-01 | Spring Washer | 33 | A51017-059-01 | Auxiliary Arm Pin |
| 14 | A51017-076-50 | Assembled Magnet Frame | ✓34 | B51017-145-50 | Auxiliary Arm |
| 15 | D51017-028-50 | Assembled Contactor Base | •*35 | Class 9998 Type HF-1 Kit | Movable Contact Tip |
| •16 | | 5/16" - 18 x 1" Hex Head Steel Cap Screw, 2 Req'd. | •*36 | | Stationary Contact Tip |
| •17 | | #10 - 24 x 3/8" Pan Head Thread Forming Screw | •*37 | | 1/4" Silicon Bronze Lock Washer, 2 Req'd. |
| •18 | | #6 - 32 x 1/4" Pan Head Screw, 2 Req'd. | •*38 | | 1/4" - 20 x 3/4" Silicon Bronze Hex Head Cap Screw, 2 Req'd. |
| ✓18 | A51018-050-50 | Assembled Connector | ✓39 | A51017-033-01 | Blowout Guard |
| 19 | A51017-102-01 | Contact Arm Pin | 40 | A51139-174-03 | Nameplate |
| •20 | | #10 - 24 x 1/2" Pan Head Screw, 2 Req'd. | •41 | | #6 - 32 x 1/4" Pan Head Screw, 2 Req'd. |
| | | | •42 | | #10 - 24 x 3/16" Flat Head Steel Screw |

Standard hardware listed without a Square D part number, should be obtained from a local hardware supplier.

NOTE: Parts Kits are Sold Only as Complete Kits and are Listed Under Class 9999 of Catalog. User Modification Kits Such as Interlocks, Tie Bars, and Timers are Listed Under Class 9998.

*Essential Parts for General Maintenance.

•Minor revision since previous issue.