



TYPE HGO - 3, SERIES B, NEMA SIZE 5, 300 AMPERE DC CONTACTOR SINGLE POLE, NORMALLY CLOSED

INSTALLATION AND ADJUSTMENT

Mount the contactor vertically on a rigid support. Provide at least 1.1" clearance above the top of the contactor base and 3.2" in front of the arc chute for arcing clearance and arc chute removal.

• With the contactor power OFF, remove the arc chute (1) and operate the contactor by hand. The contact tips should meet squarely. If they do not, adjust by the procedure described below in step 6 of "Contact Tip Replacement". When released, the contactor should close quickly and completely. If it does not, check for the impaired operation of the contact arm assembly. Check all electrical connections to see that they are tight and replace the arc chute. No further adjustments are necessary.

CAUTION: Do not operate the contactor under load without the arc chute installed in its proper position.

TROUBLESHOOTING

PROBLEM: Contactor will not open when energized.

• **SOLUTION:** Check the voltage at the operating coil terminals. An absence of voltage indicates a fault elsewhere in the circuitry. If the coil voltage is normal, disconnect the coil leads and check the coil for proper resistance. Resistance values for standard coils are listed in the parts list on page 2. Resistance values for other coils are listed in the Class 9998 Magnet Coil Application Data catalog sheet. An open or shorted coil must be replaced.

REPAIR and MAINTENANCE

CONTACT TIP REPLACEMENT

To determine when the contact tips should be replaced, the contact follow up must be measured. The contact follow up is the distance "F" measured at the upper edge of the contact arm with the contactor fully closed, as shown on the right. When this distance is reduced to 1/16" or less, the contact tips must be replaced to assure that proper contact pressure is maintained.

Should it be necessary to replace the tips, a 1/2" open end wrench is the only tool needed and the following procedure should be followed:

1. Remove the arc chute (1).
- 2. Unscrew the hex head bolt (43) holding the flexible connector and movable contact tip in place.
- 3. Remove these parts and unscrew the hex head bolt (43) holding the stationary contact tip in place.
- 4. Install a new stationary contact tip (42) and replace the bolt (43)*
- 5. Reassemble the new movable contact tip (41), flexible connector (20), and bolt (43)* in that order.

6. Operate the contactor by hand to see that the tips meet squarely. Contact tip alignment can be adjusted by loosening the tip retaining bolts and shifting the tips. After the contacts are properly aligned, retighten the bolts securely.
7. Replace the arc chute.

COIL REPLACEMENT

To replace the operating coil, a screwdriver and 1/2" open end wrench are needed and the following procedure should be followed:

1. Remove the arc chute.
2. Remove the coil leads.
3. Loosen the two pan head screws (28) and push the contact arm pin (31) out.
4. Remove the contact arm assembly and closing spring (24).
5. Unscrew the 2 bolts (11) holding the assembled magnet frame (16) and coil in place.
6. Remove the magnet frame and coil from the contactor and unscrew the 4 screws (23) holding the core cap (22) to the magnet core.
7. Remove the core cap and coil.

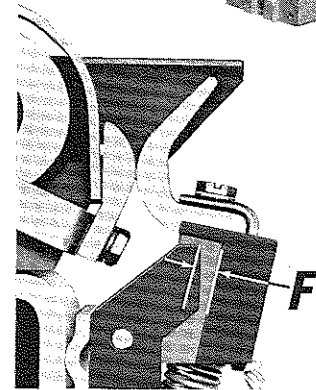
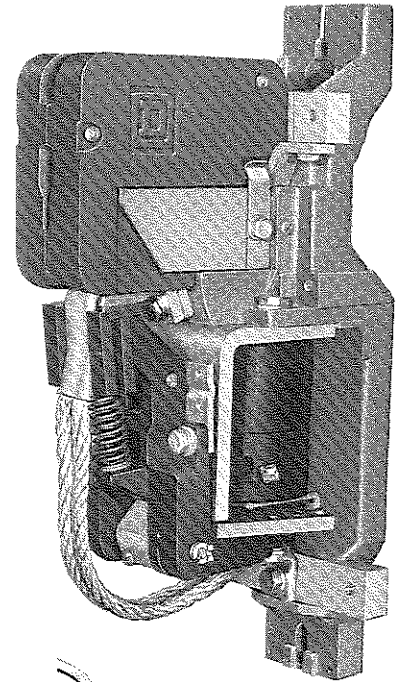

8. Install the new coil and replace the core cap.
9. Reassemble the magnet frame and coil to the contactor base and replace the 2 bolts (11) holding it.
10. Replace the closing spring (24), the contact arm assembly, the contact arm pin (31) and tighten the two pan head screws (28).
11. Reconnect the coil leads and replace the arc chute.

LUBRICATION

The type "H" contactor requires no lubrication. The pivot pins bear in a self-lubricating material.

NOTE: *The special non-magnetic bolts and lockwashers supplied with the contact parts kit must be used.

•Minor revision since previous issue.

Supersedes SB 7004-54 Dated 12-71

PRINTED
IN
U.S.A.

SQUARE D COMPANY

P. O. Box 9247
Columbia, S.C. 29290

2.5M



TYPE HGO-3, SERIES B, NEMA SIZE 5, 300 AMPERE, DC CONTACTOR, S.P., N.C.

Item No.	Part No.	Description
* 1	A51019-035-50	Assembled Arc Chute
2	B50512-052-34	Blowout Core Insulator
3	B50502-776-15	Blowout Core
• 4		3/8"-16x3/4" Hex Head Steel Cap Screw
• 5		3/8" Plain Lock Washer, 3 Req'd.
6	A51019-054-50	Blowout Coil and Top Terminal Block Assembly
7	A51019-032-01	Blowout Ear, 2 Req'd.
8	A51019-034-01	Arc Chute Spring, 2 Req'd.
• 9		5/16" Plain Lock Washer, 8 Req'd.
• 10		5/16"-18x5/8" Hex Head Steel Cap Screw, 2 Req'd.
• 11		5/16"-18x7/8" Hex Head Slotted Steel Screw, 4 Req'd.
• 12		5/16" Plain Washer, 6 Req'd.
13	D51019-028-50	Assembled Contactor Base
• 14		3/8"-16x1" Hex Head Steel Cap Screw 2 Req'd.
• 15		#10-24x3/8" Pan Head Thread Forming Screw
16	A51019-076-51	Assembled Magnet Frame
17	A51019-041-01	Spring Washer
• 18	A51017-067-51	Assembled Operating Coil (240V Approximate Resistance 1372 ohms)
	A51017-067-54	Assembled Operating Coil (120V Approximate Resistance 354 ohms)
• 19	A51019-052-01	Bottom Terminal Block
20	A51019-050-50	Assembled Connector
21	A51019-070-50	Assembled Coil Core
22	A51019-072-01	Core Cap
†23		#10-24x3/8" Flat Head Steel Screw, 4 Req'd.
24	B50502-602-10	Closing Spring
†25		#10-24x3/8" Pan Head Screw
26	A51019-071-01	Core Cap Spacer
27	A51019-043-01	Armature
• 28		#10-24x5/8" Pan Head Screw, 2 Req'd. (Included in Item 16)
• 28A		#10 Plain Lock Washer
• 29		#6-32x1/4" Pan Head Type F Tapping Screw, 2 Req'd.
30	A51139-176-02	Nameplate
31	A51019-102-01	Contact Arm Pin
• 32		5/16"-18x5/8" Hex Head Slotted Steel Screw, 2 Req'd.
33	B50502-602-11	Auxiliary Arm Spring
• 34	29907-02010	E Rings, 2 Req'd.
35	A51019-103-50	Contact Arm Assembly with Bushings

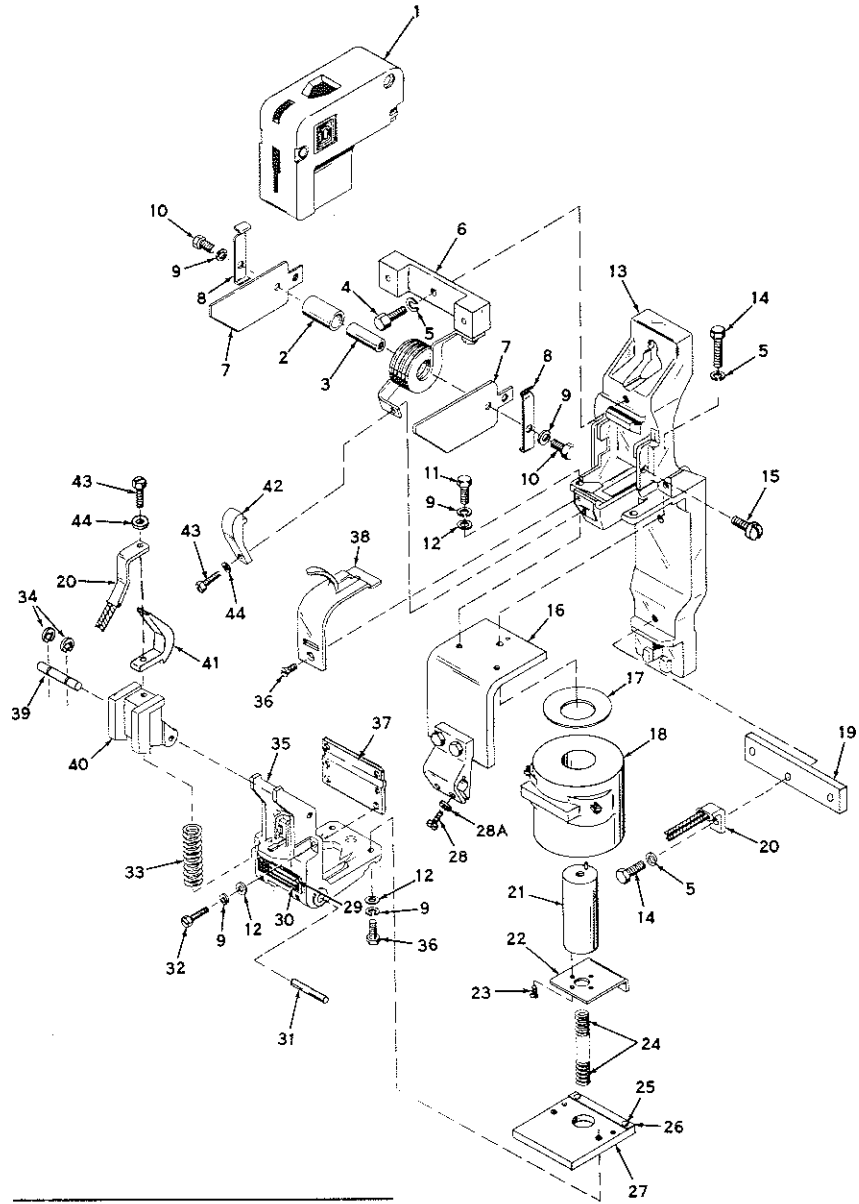

Item No.	Part No.	Description
• 36		5/16"-18x3/4" Flat Head Steel Screw
37	A51019-073-01	Stop Plate
38	A51019-033-01	Blowout Guard
39	A51019-059-01	Auxiliary Arm Pin
40	B51019-145-50	Auxiliary Arm
*41	Class 9998 Type HG-1 Kit	Movable Contact Tip
*42		Stationary Contact Tip
*43		5/16"-18x1" Silicon Bronze Cap Screw, 2 Req'd.
*44		5/16" Silicon Bronze Lock Washer, 2 Req'd.

■ Standard hardware listed without a Square D part number, should be obtained from a local hardware supplier.

NOTE: Parts Kits are Sold Only as Complete Kits and are Listed Under Class 9999 of Catalog. User Modification Kits Such as Interlocks, Tie Bars, and Timers are Listed Under Class 9998.

*Essential Parts for General Maintenance.
 †Use "Locktite EV" sealant before assembling.
 •Minor revision since previous issue.