



## TYPE HHO-1, SERIES A, NEMA SIZE 6, 600 AMPERE, DC CONTACTOR SINGLE POLE, NORMALLY OPEN

### INSTALLATION AND ADJUSTMENT

- Mount the contactor vertically on a rigid support. Provide at least 3.2" clearance above the top of the arc chute and 4.0" in front of the arc chute for arcing clearance and arc chute removal.

- With the contactor power OFF, lift straight up on the arc chute (1) and remove it from the contactor. It may then be placed in the arc chute bracket (6) to prevent loss or damage. Operate the contactor by hand to see that the contact tips meet squarely. If they do not, adjust by the procedure described below in step 6 of "Contact Tip Replacement." When released the contactor should open freely. If it does not, check for the impaired operation of the contact arm assembly. On multi-pole contactors, check also for binding of the tie bar. Check all electrical connections to see that they are tight and replace the arc chute. No further adjustments are necessary.

**CAUTION:** Do not operate the contactor under load without the arc chute installed in its proper position.

### TROUBLESHOOTING

**PROBLEM:** Contactor will not close when energized.

- SOLUTION:** Check the voltage at the operating coil terminals. An absence of voltage indicates a fault elsewhere in the circuitry. If the coil voltage is normal, disconnect the coil leads and check the coil for proper resistance. Resistance values for standard coils are listed in the parts list on page 3. Resistance values for other coils are listed in the Class 9998 Magnet Coil Application Data catalog sheet.

### REPAIR and MAINTENANCE

#### CONTACT TIP REPLACEMENT

To determine when the contact tips should be replaced, the contact follow up must be measured. The contact follow up is the distance "F" measured at the upper edge of the contact arm with the contactor fully closed, as shown on the right. When this distance is reduced to 1/16" or less, the contact tips must be replaced to assure that proper contact pressure is maintained.

- Should it be necessary to replace the tips, a 1/2" wrench is the only tool needed and the following procedure should be followed:

- Remove the arc chute (1).
- Unscrew the hex head bolts (18B), holding the flexible connector and movable contact tip in place.
- Remove these parts and unscrew the hex head bolts (15) holding the stationary contact tip in place.
- Install a new stationary contact tip (14), and replace the bolt (15).\*
- Reassemble the new movable contact tip (17), flexible con-

ductor (19B), and bolt (18A), in that order.

- Operate the contactor by hand to see that the tips meet squarely. Contact tip alignment can be adjusted by loosening the tip retaining bolts and shifting the tips. After the contacts are properly aligned, retighten the bolts securely.

- Replace the arc chute.

#### COIL REPLACEMENT

- To replace the operating coil, a screwdriver and 1/2" wrench are needed and the following procedure should be followed:

- Remove the arc chute.
- Remove the coil leads.
- Loosen both hex head cap screws (40), and remove the contact arm pin (27).
- Remove the contact arm assembly.
- Unscrew the hex head bolt (33) on the top of the coil core and remove the core cap (35), core spacer (34) and the coil.
- Install the new coil and replace the core cap spacer (34), core cap

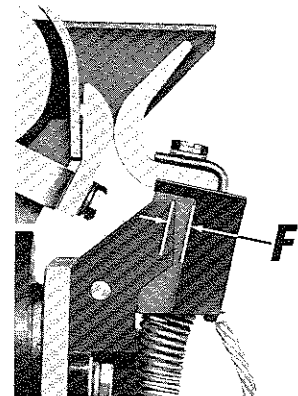
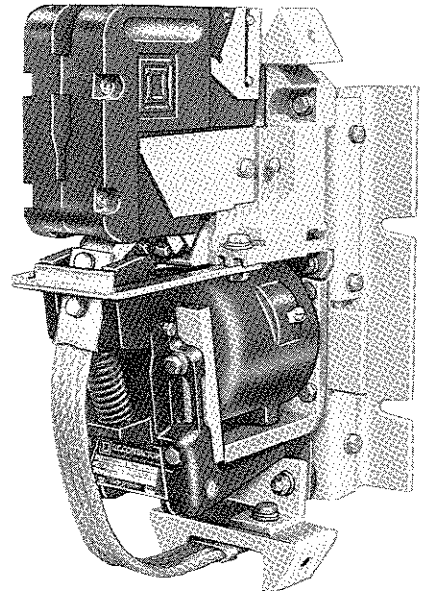

(35), lock washer (10) and hex head bolt (33). Make sure the core cap (heavy steel washer) is next to the coil. (Note that the coil spring washer (37) is positioned concave side towards the coil.)

- Replace the contactor arm assembly, contact arm pin (27), and tighten the two hex head cap screws (40).
- Reconnect the coil leads to the coil and replace the arc chute.

#### LUBRICATION

The Type H contactor requires no lubrication. The pivot pins bear in a self-lubricating material.

**NOTE:** \* The special non-magnetic bolts and lockwashers supplied with the contact parts kit must be used.

- Minor revision since previous issue.



**TYPE HHO-1, SERIES A, NEMA SIZE 6, 600 AMPERE,  
DC CONTACTOR, S.P., N.O.**

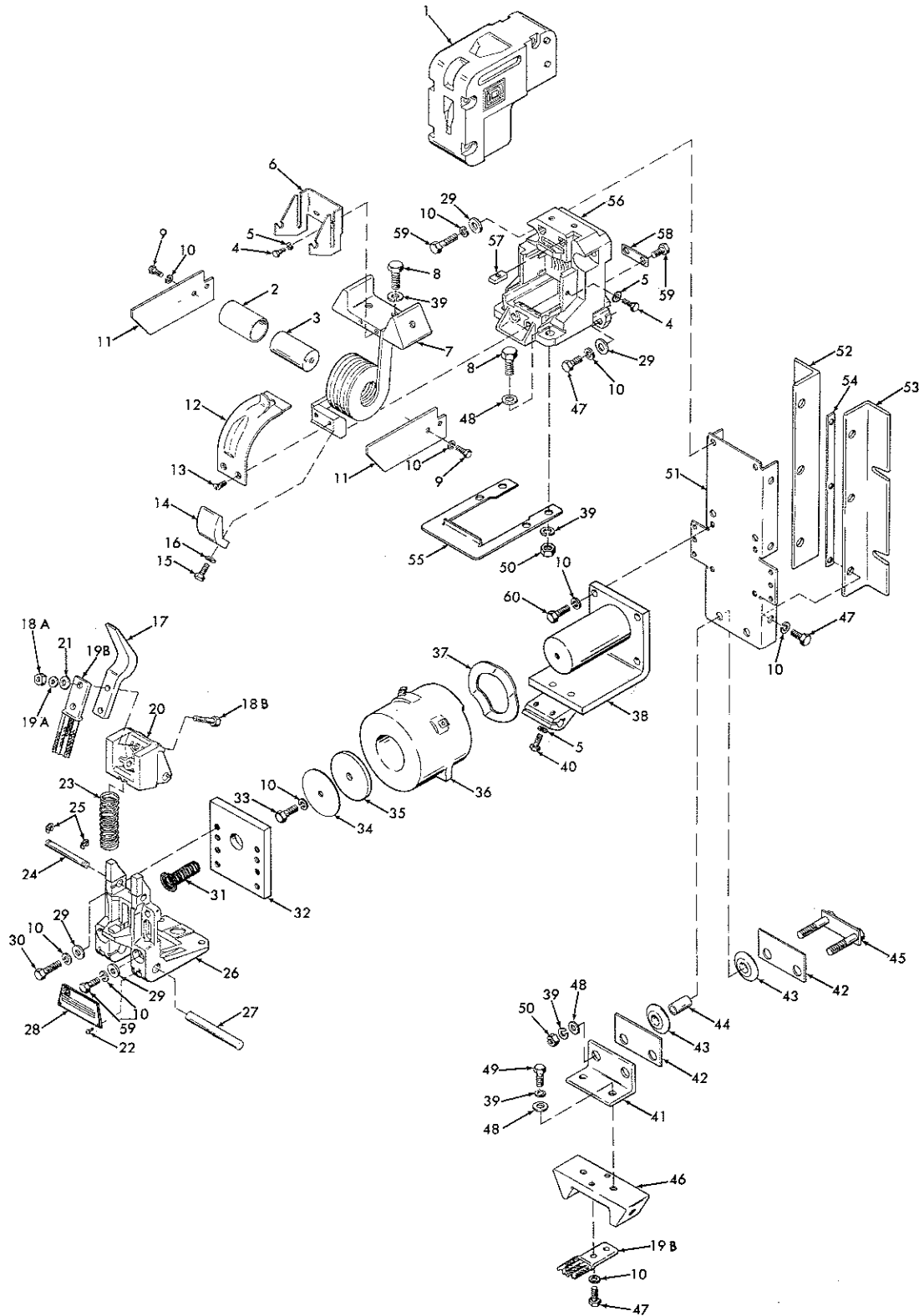



**TYPE HHO-1, SERIES A, NEMA SIZE 6, 600 AMPERE,  
DC CONTACTOR, S.P., N.O.**

Item No.	Part No.	Description	Item No.	Part No.	Description
† 1.	A51020-035-50	Assembled Arc Chute	32.	A51020-043-01	Armature
2.	B50512-052-46	Blowout Core Insulator	● 33.		5/16"-18x3/4" Hex Head Steel Screw
3.	B50502-776-16	Blowout Core	34.	B50502-006-15	Core Cap Spacer
● 4.		1/4"-20x1/2" Hex Head Steel Screw. 3 Req'd.	35.	B50502-006-14	Core Cap
● 5.		1/4" Plain Lock Washer. 3 Req'd.	† 36.	C51020-056-71	Assembled Operating Coil (240V—Approximate Resistance 567 ohms.)
6.	B51020-065-01	Arc Chute Bracket		C51020-056-74	Assembled Operating Coil (120V—Approximate Resistance 141 ohms.)
7.	A51020-054-50	Blowout Coil and Top Terminal Block Assembly	37.	A51020-041-01	Spring Washer
● 8.		3/8"-16x1-1/4" Hex Head Steel Screw. 4 Req'd.	38.	A51020-037-50	Assembled Magnet Frame
● 9.		5/16"-18x5/8" Hex Head Steel Screw. 2 Req'd.	● 39.		3/8" Plain Lock Washer. 8 Req'd.
● 10.		5/16" Plain Lock Washer. 23 Req'd.	● 40.		1/4"-20x7/8" Hex Head Slotted Cap Screw. 2 Req'd.
† 11.	A51020-032-01	Blowout Ear	41.	A51020-060-01	Bottom Terminal Mounting Bracket
12.	B51020-033-01	Blowout Guard	42.	A51020-092-01	Isolator. 2 Req'd.
● *13.		# 10-24x3/8" Flat Head Steel Screw. 2 Req'd.	43.	A51020-059-01	Insulator. 4 Req'd.
● † 14.		Stationary Contact Tip	44.	A51020-062-01	Bushing. 2 Req'd.
† 15.		5/16"-18x1" Hex Head Silicon Bronze Screw. 2 Req'd.	45.	A51020-024-50	Assembled Terminal Mounting Strip
	<b>Class 9998</b>		46.	A51020-061-01	Bottom Terminal Block
† 16.	<b>Type HH-1</b>	5/16" Silicon Bronze Lock Washer. 2 Req'd.	● 47.		5/16"-18x3/4" Hex Head Steel Screw. 11 Req'd.
† 17.	<b>Kit</b>	Movable Contact Tip	● 48.		3/8" Plain Washer. 4 Req'd.
† 18A.		5/16"-18 Hex Steel Jam Nut. 2 Req'd.	● 49.		3/8"-16x3/4" Hex Head Steel Screw. 2 Req'd.
† 18B.		5/16"-18x1-1/2" Hex Head Steel Screw. 2 Req'd.	● 50.		3/8"-16 Hex Steel Nut. 2 Req'd.
† 19A.		5/16" Spring Belleville Washer. 2 Req'd.	51.	A51020-025-01	Mounting Pan
● 19B.	A51020-050-50	Assembled Connector.	52.	B51020-026-01	Insulating Support. (Left Hand)
● 20.	A51020-075-50	Auxilliary Arm with Bushings	53.	B51020-026-02	Insulating Support. (Right Hand)
● 21.	23903-32003	5/16" Plain Washer. 2 Req'd.	54.	A51020-027-01	Mounting Strip
● 22.		# 6-20x1/4" Pan Head Screw. 2 Req'd.	55.	A51020-053-01	Stop Plate
23.	B50502-602-16	Auxiliary Arm Spring	56.	D51020-028-01	Contacto Base
24.	A51020-046-01	Auxiliary Arm Pin	57.	A51020-091-01	Reinforcing Nut. 2 Req'd.
25.	29907-02410	"E" Ring. 2 Req'd.	58.	A51020-052-01	Locking Plate
● 26.	A51020-074-50	Contact Arm with Bushings	● 59.		5/16"-18x1-1/2" Hex Head Steel Screw. 4 Req'd.
27.	A51020-047-01	Contact Arm Pin	● 60.		5/16"-18x7/8" Hex Head Steel Screw. 6 Req'd.
● 28.	A51139-180-01	Nameplate			
● 29.		5/16" Plain Washer. 8 Req'd.			
● 30.		5/16"-18x1" Hex Head Steel Screw. 2 Req'd.			
31.	B50502-602-17	Opening Spring			

■ Standard hardware, listed without a Square D part number, should be obtained from a local hardware supplier.

† Essential Parts for General Maintenance

\* Use Locktite "EV" Sealant

● Minor Revisions Since Previous Issue.

